

Ritsumeikan University
Soft Robotics
November 17/24, 2023
16:20-17:50

Soft Actuators

Jun Shintake

Department of Mechanical and Intelligent Systems Engineering,
The University of Electro-Communications (UEC), Tokyo, Japan.



Soft actuators

- Made of compliant materials
- Materials or compliant structures themselves deform by external stimuli (*stimuli \approx inputs)
- Simpler than conventional rigid actuators
- Often called as Artificial Muscle
- Examples:

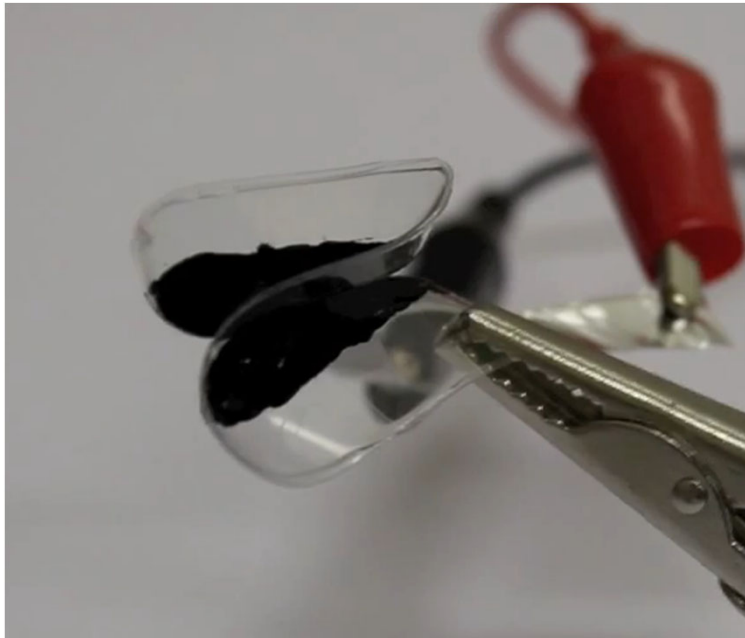

Electrical soft actuator

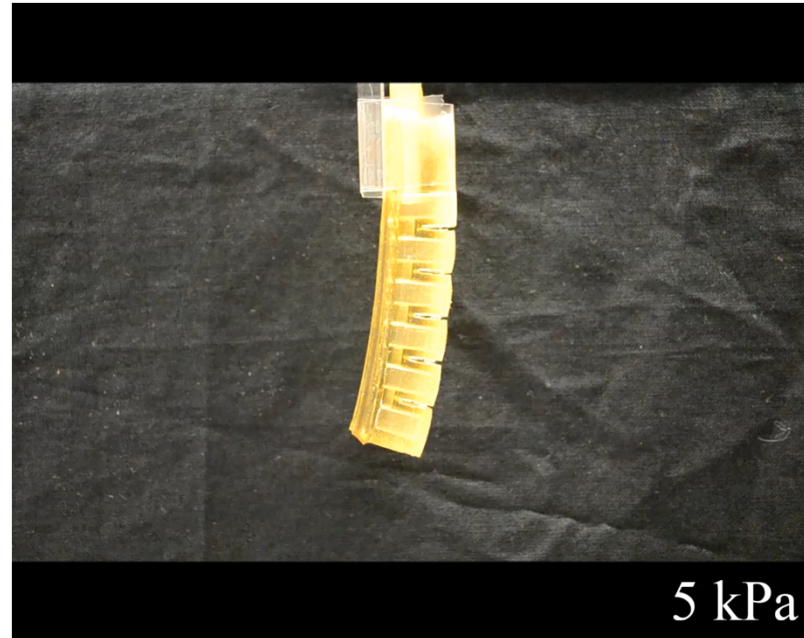

Fluidic soft actuator

Soft actuators

They rely on stimuli of:

- Electric
- Magnetic
- Thermal
- Light
- Pressure

Under which many sub-classes and configurations are being developed.

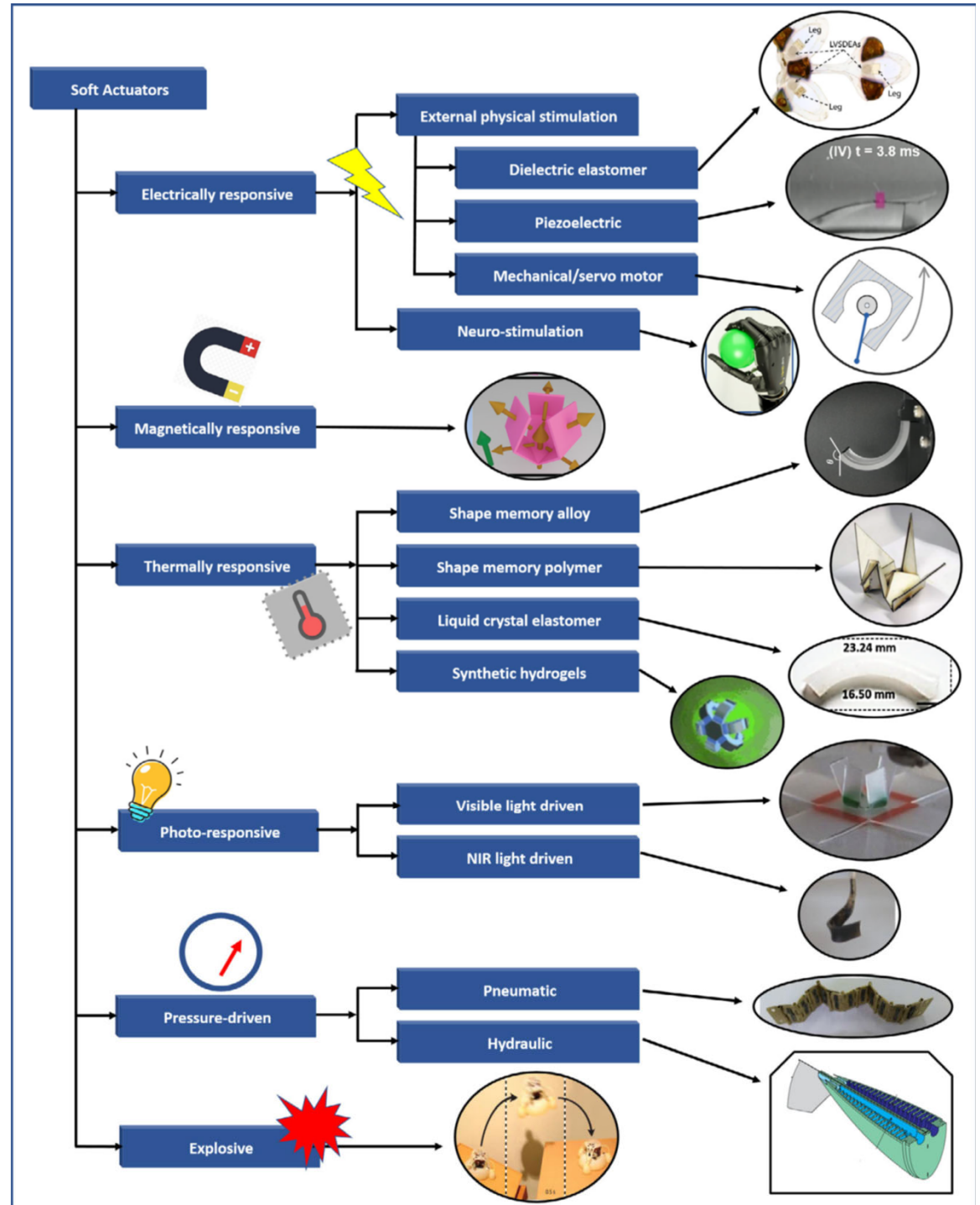

Aim of the topic “Soft Actuators”

~~11/17: Detail a single soft actuator technology and describe how it enables various actuator configurations and robotic systems.~~

11/24: Overview existing soft actuators and discuss their pros and cons*, followed by homework.

*Focus on representative (i.e., widespread) soft actuator technologies.

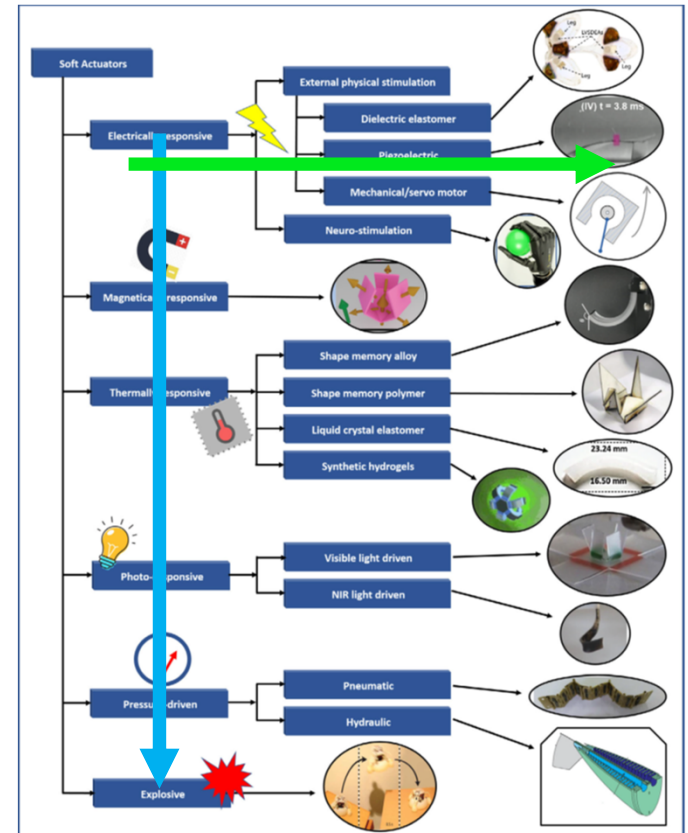

El-Atab, Nazek, et al. "Soft actuators for soft robotic applications: A review." Advanced Intelligent Systems 2.10 (2020): 2000128.

Class of key soft actuator technologies

- **Pressure responsive**
 - Fluidic elastomer actuators
 - McKibben actuators
 - Film based soft actuators
- **Electrically responsive**
 - Electroactive polymers
 - Electro-hydraulic soft actuators
 - Biohybrid actuators
- **Thermally responsive**
 - Fishing line artificial muscles
 - Shape memory alloys
 - Shape memory polymers
- **Magnetically responsive**
 - Magnetic elastomer actuators

Provide basic principle and share movies to show movements of actuators and robots for getting a better insight.



Shintake, Jun, et al. "Bio-inspired tensegrity fish robot." 2020 IEEE International Conference on Robotics and Automation (ICRA). IEEE, 2020.

Pressure responsive soft actuators

- Fluidic elastomer actuators
 - McKibben actuators
 - Film based soft actuators
-
- All of them exploit inflation of the actuator structure by pressurization of gas (e.g., air) or liquid (e.g., water).
 - Easy to make (by molding, 3D printing, heat sealing), high actuation output, relatively fast, require external pumps and compressors.

Pressure responsive soft actuators: Fluidic elastomer actuators

- Also called as “Elastic inflatable actuators (EIAs)”, “Pneumatic soft actuators (SPAs)”, etc.
- Base material: Silicone rubbers

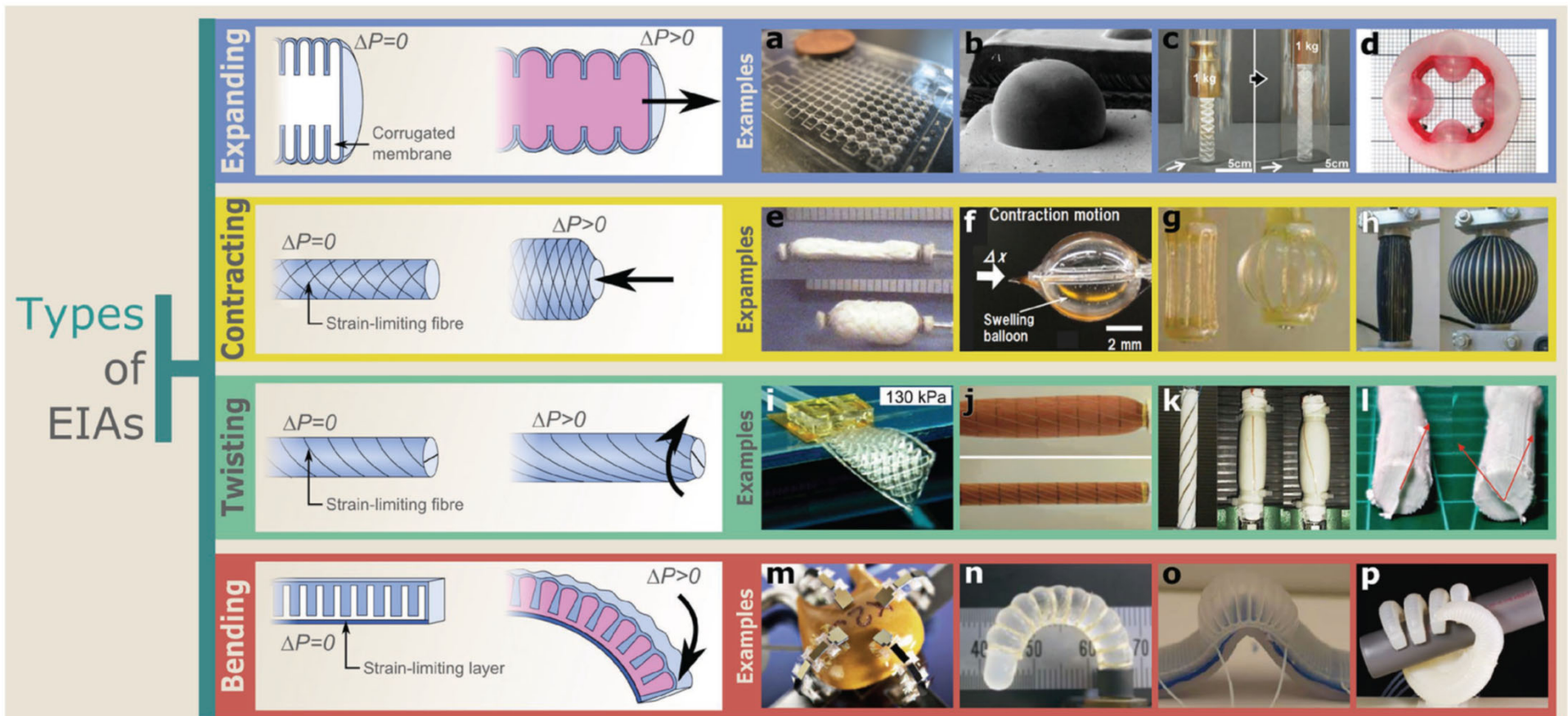

Pressure responsive soft actuators: Fluidic elastomer actuators

- Bending type is most common actuator configuration

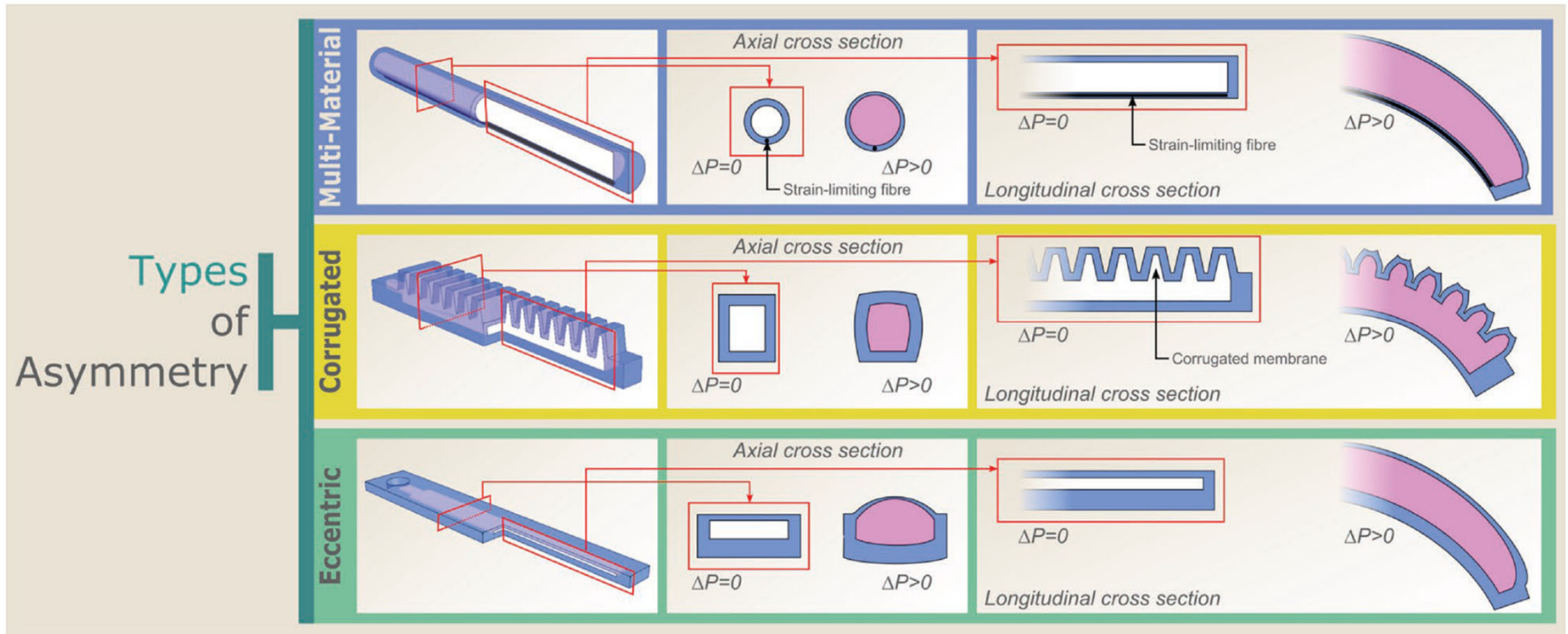

Pressure responsive soft actuators: Fluidic elastomer actuators



“膨らんで曲がるシリコンアクチュエータ”

<http://opensoftmachines.com/2018/03/silicone-bending-actuator/?lang=ja>

Pressure responsive soft actuators: Fluidic elastomer actuators



Suzumori, Koichi, Shoichi Iikura, and Hirohisa Tanaka. "Development of flexible microactuator and its applications to robotic mechanisms." Proceedings. 1991 IEEE International Conference on Robotics and Automation. IEEE Computer Society, 1991.

Soft Robotics 01: Flexible Microactuator
<https://www.youtube.com/watch?v=kHGLYRUKWeM>

Pressure responsive soft actuators: Fluidic elastomer actuators

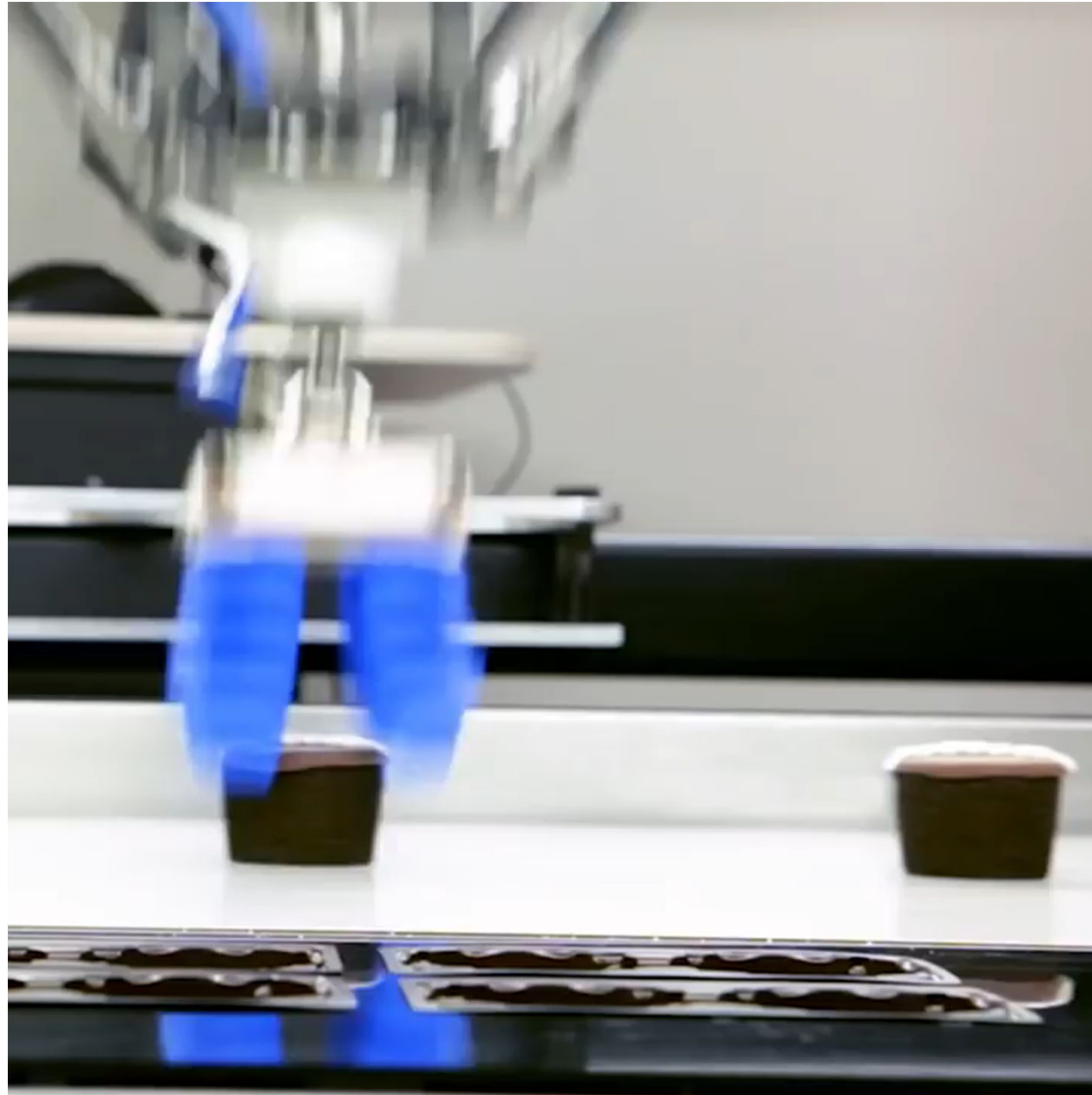

'Soft Robots' Handle Food With Care
<https://www.youtube.com/watch?v=gngaoJ--9Q>

Pressure responsive soft actuators: Fluidic elastomer actuators

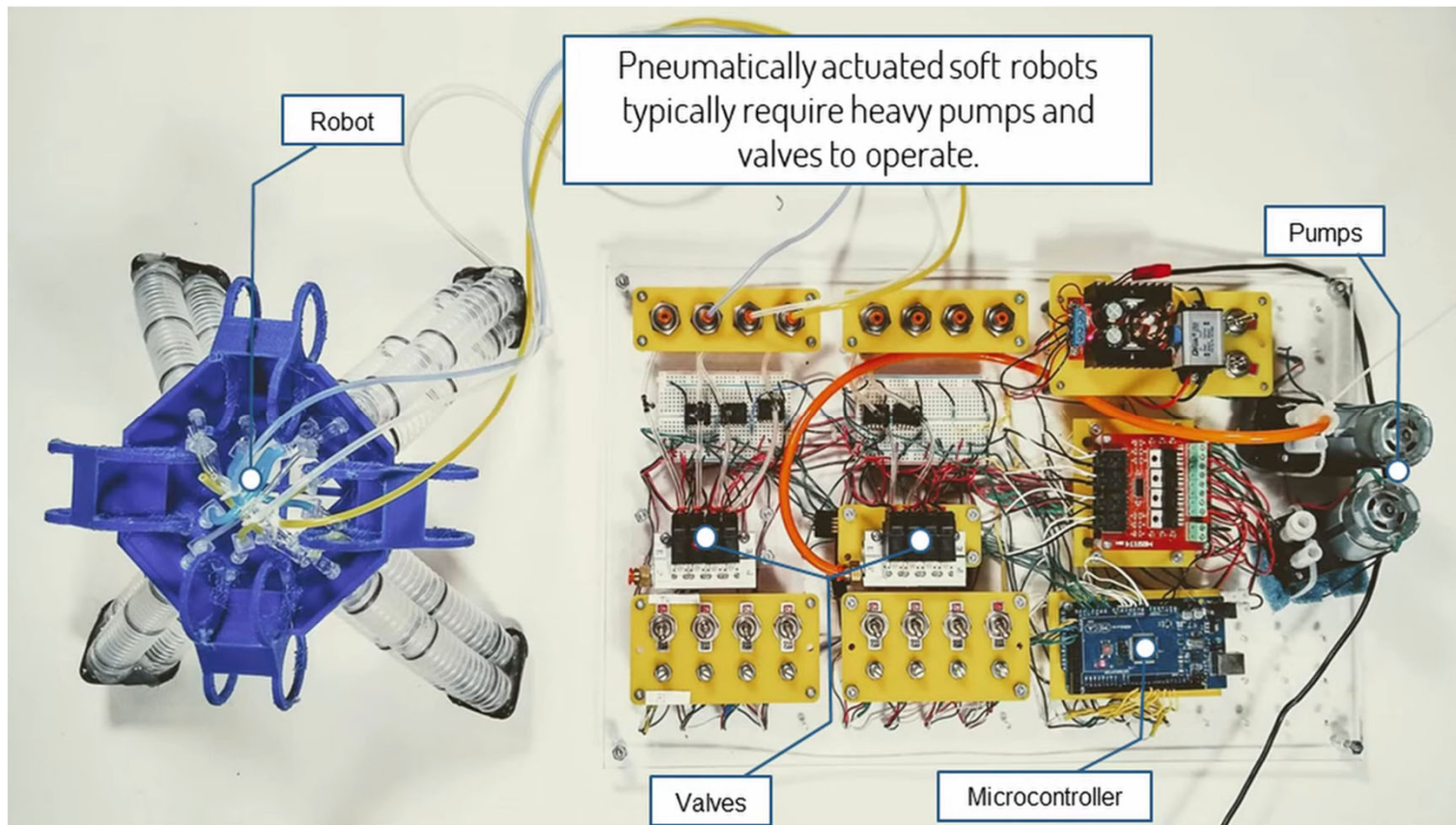

Drotman, Dylan, et al. "Electronics-free pneumatic circuits for controlling soft-legged robots." *Science Robotics* 6.51 (2021): eaay2627.

Electronics-Free Soft Legged Robot
<https://www.youtube.com/watch?v=bnT6BBkDYlc>

Pressure responsive soft actuators: Fluidic elastomer actuators

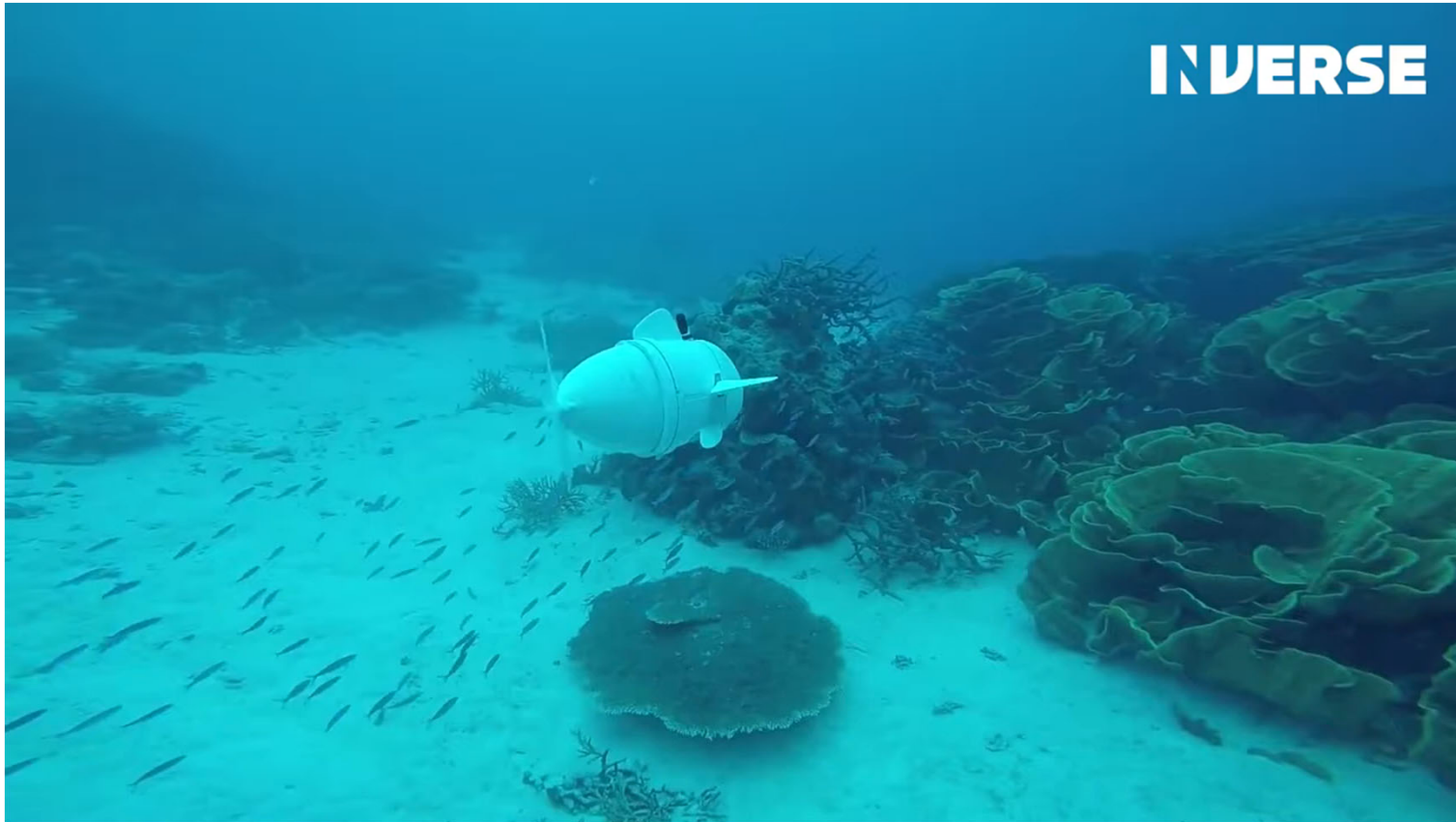

Katzschmann, Robert K., et al. "Exploration of underwater life with an acoustically controlled soft robotic fish." *Science Robotics* 3.16 (2018): eaar3449.

SoFi MIT Robot Fish | Inverse
<https://www.youtube.com/watch?v=2vy861m2MAE>

Pressure responsive soft actuators: Fluidic elastomer actuators

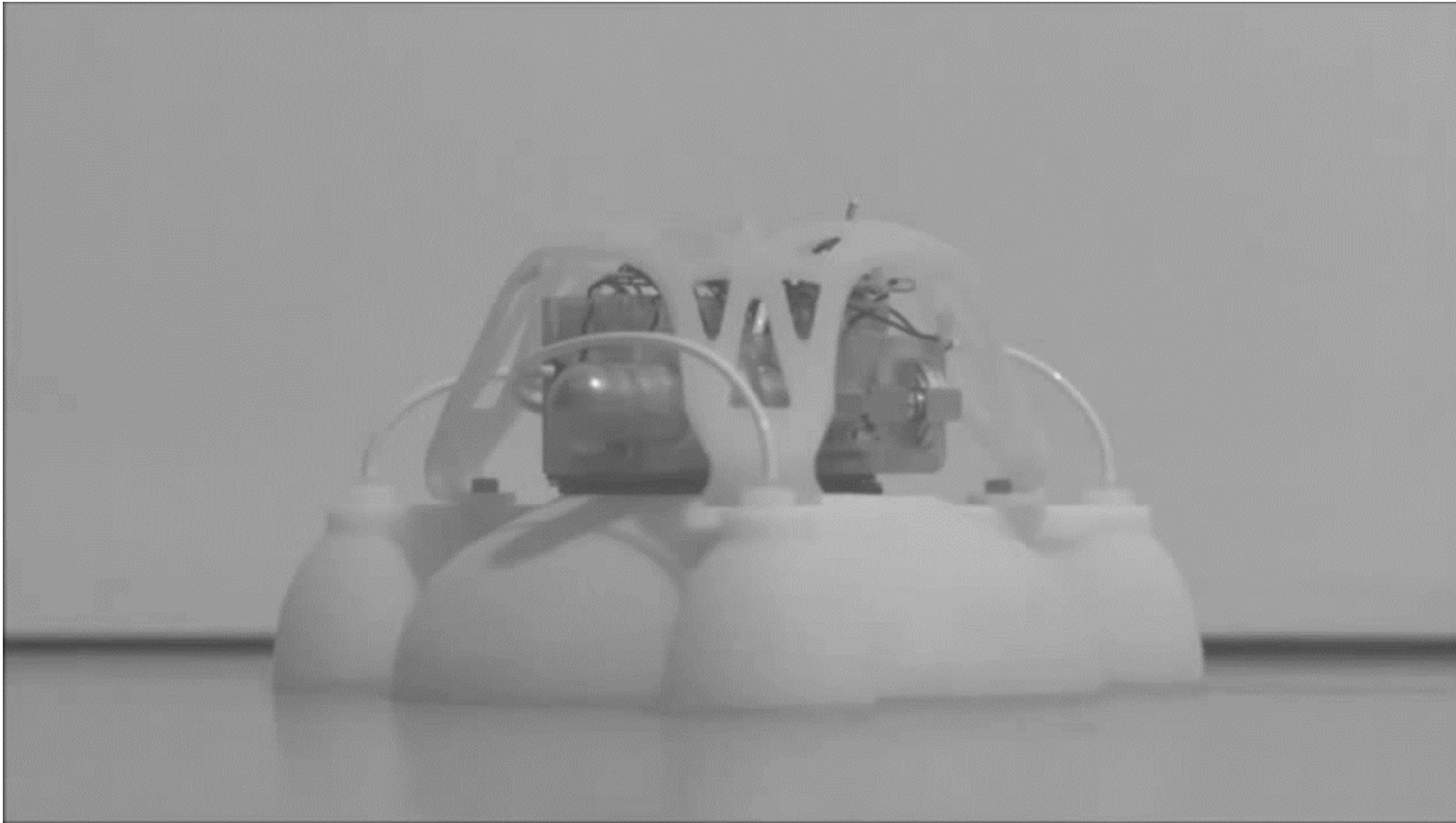

A 3-D Printed Functionally Graded Soft Robot
<https://www.youtube.com/watch?v=u5F4ECFGgJ8>

Bartlett, Nicholas W., et al. "A 3D-printed, functionally graded soft robot powered by combustion." *Science* 349.6244 (2015): 161-165.

Pressure responsive soft actuators: McKibben actuators

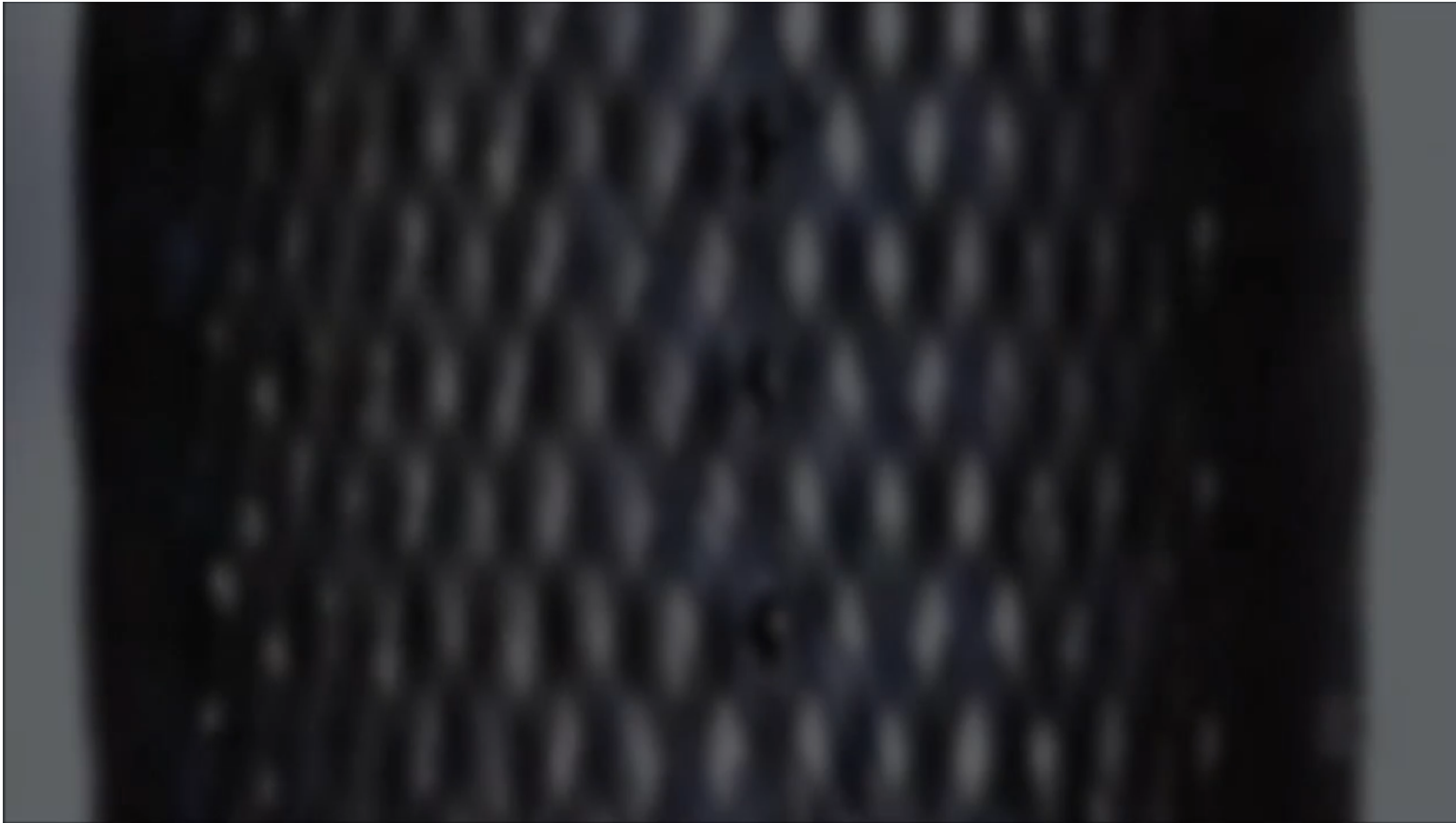

Pressure responsive soft actuators: Mckibben actuators



THE UNIVERSITY OF TOKYO

Jumping & Landing Robot "MOWGLI" with Artificial Musculoskeletal System

Ryuma Niiyama, Yasuo Kuniyoshi



Copyright © 2007 ISI Lab.

Pressure responsive soft actuators: Film based soft actuators

- Also called as “Pouch motors”.
- Base material: Inextensible films (e.g., Oriented Polypropylene (OPP))

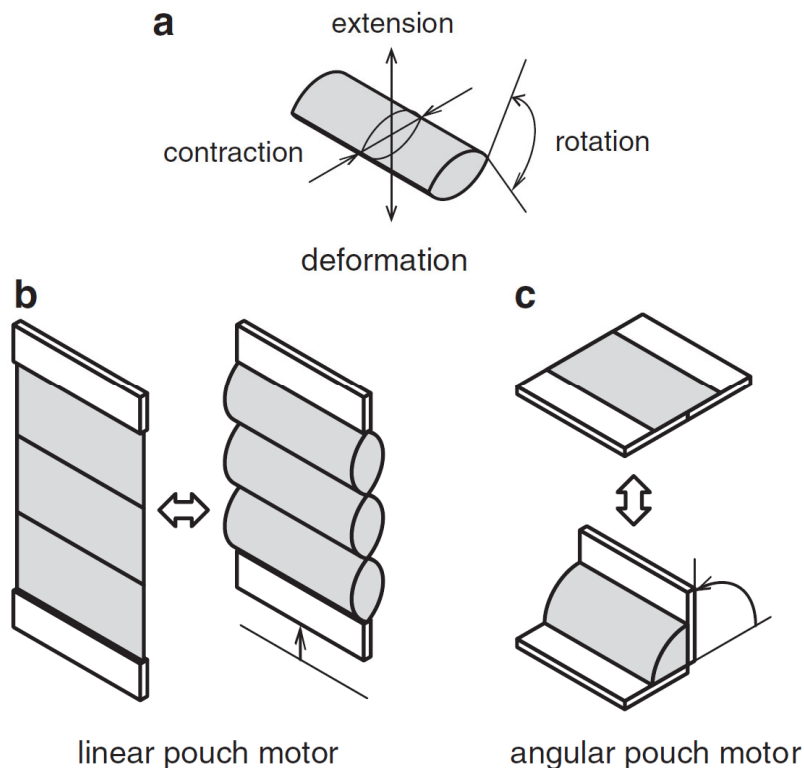

Electrically responsive soft actuators

- Electroactive polymers
- Electro-hydraulic soft actuators
- Biohybrid actuators

Electrically responsive soft actuators: Electroactive polymers: Dielectric elastomer actuators (DEAs)

- Work with electrostatic force between the electrodes.
- Large deformation, fast movements but often low force and require high voltage.
- Common material: Silicone rubbers

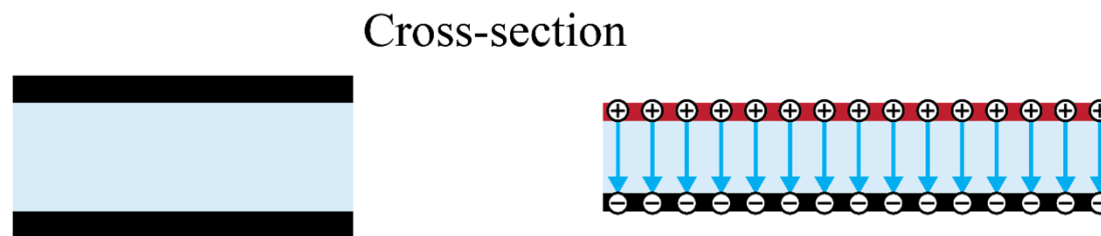
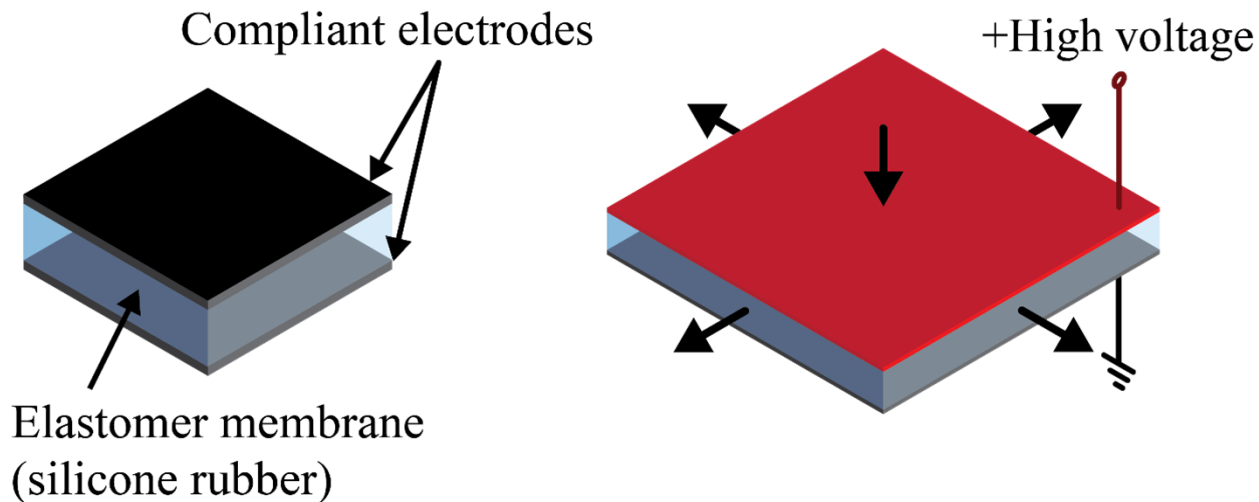

← Electric field ■ High voltage ■ Ground

Electrically responsive soft actuators:
Electroactive polymers:
Dielectric elastomer actuators (DEAs)

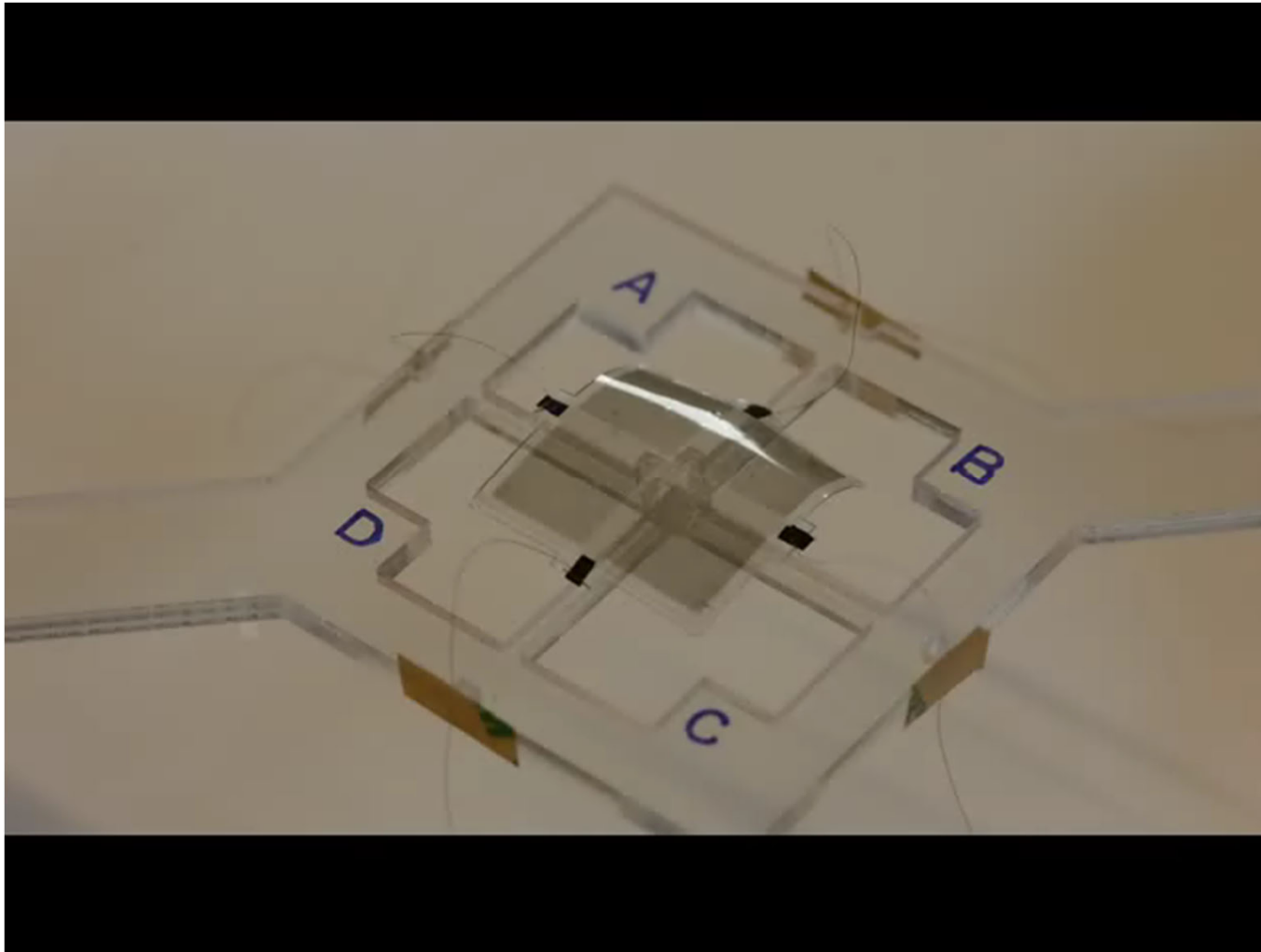

Electrically responsive soft actuators:
Electroactive polymers:
Dielectric elastomer actuators (DEAs)

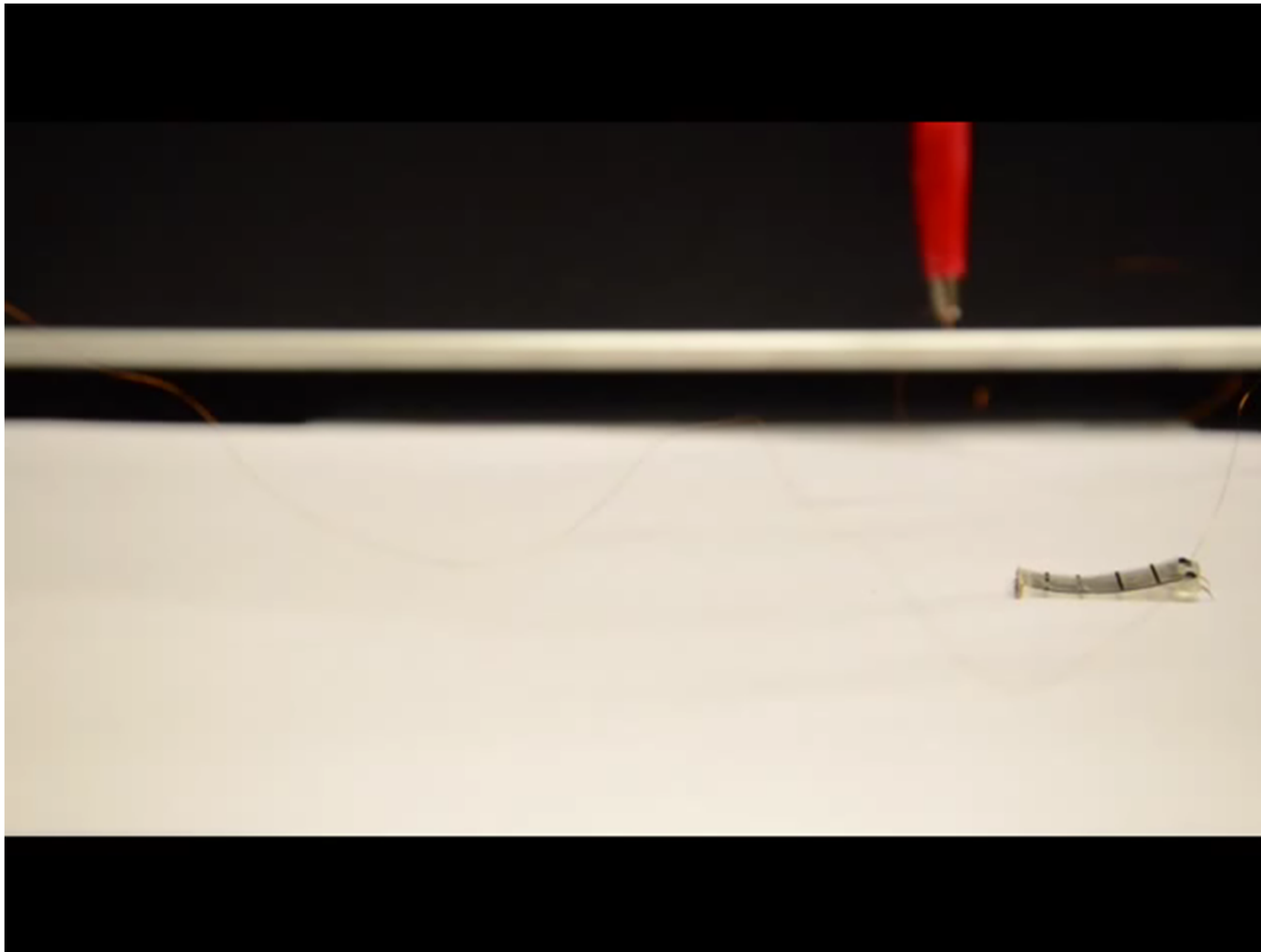

Electrically responsive soft actuators: Electroactive polymers: Dielectric elastomer actuators (DEAs)

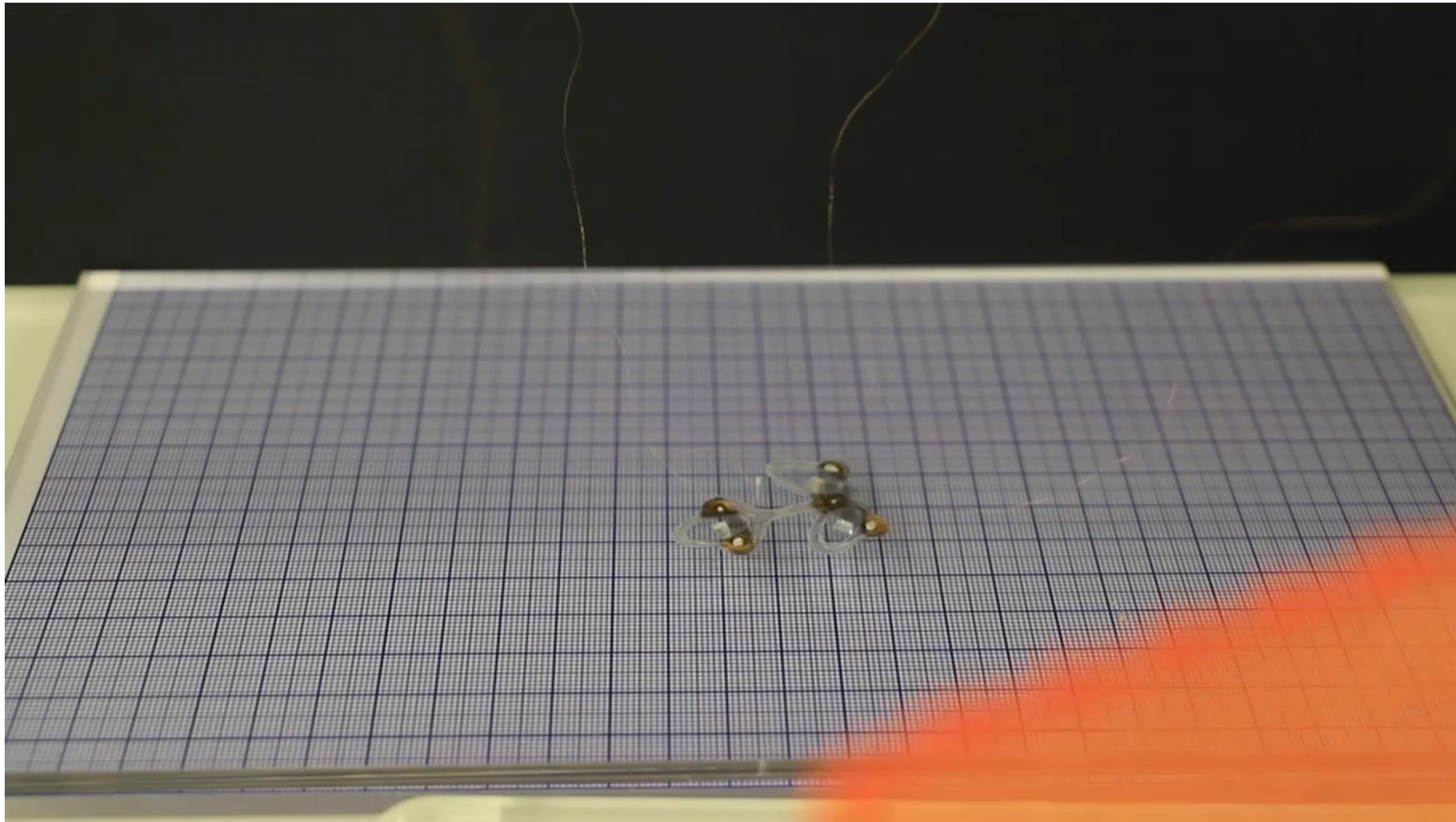

A soft robotic insect that survives being flattened by a fly swatter
https://www.youtube.com/watch?v=s_qhmBsG_ZQ

Ji, Xiaobin, et al. "An autonomous untethered fast soft robotic insect driven by low-voltage dielectric elastomer actuators." *Science Robotics* 4.37 (2019): eaaz6451.

Electrically responsive soft actuators: Electroactive polymers: Dielectric elastomer actuators (DEAs)

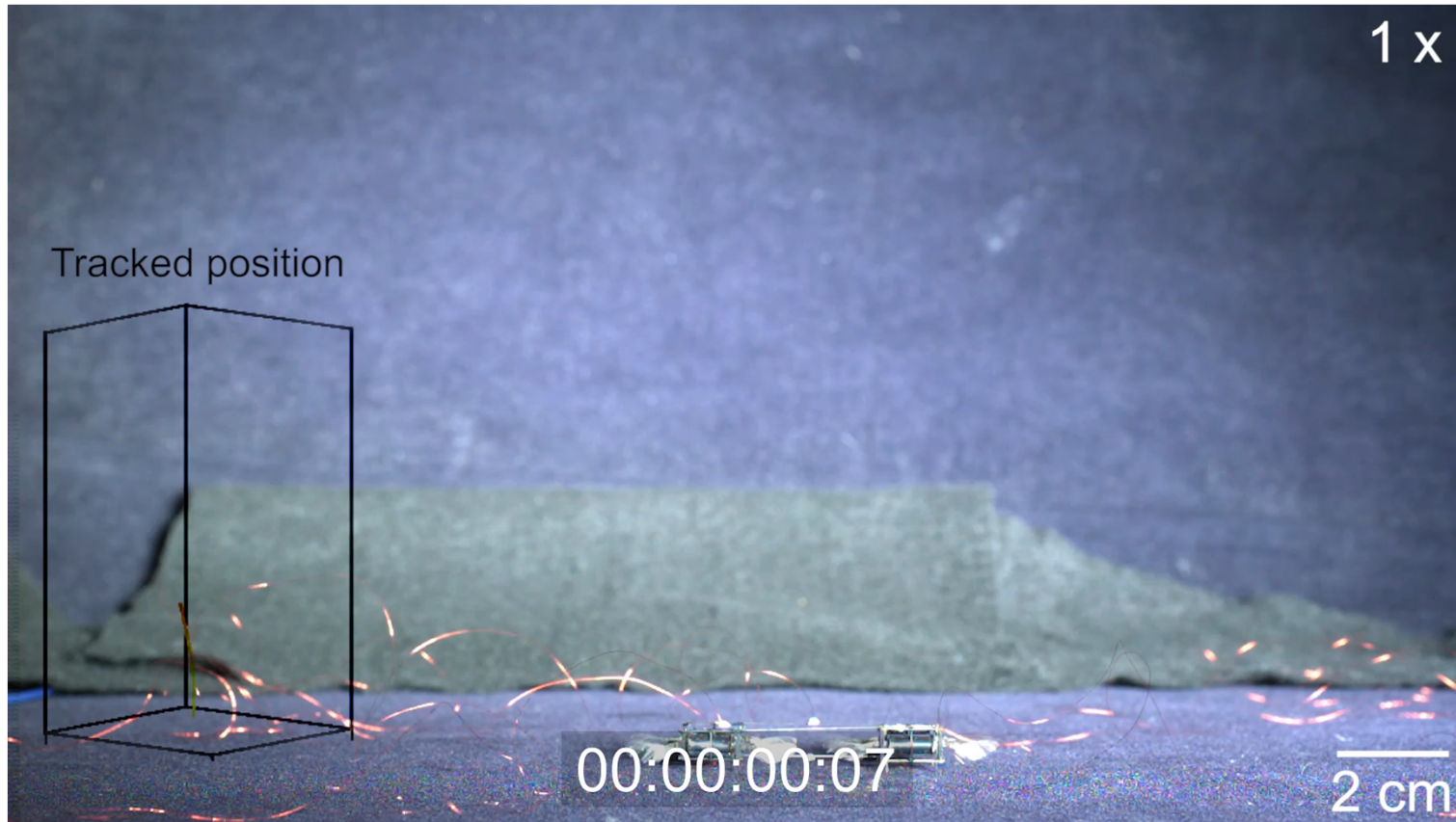

Electrically responsive soft actuators: Electroactive polymers: Dielectric elastomer actuators (DEAs)

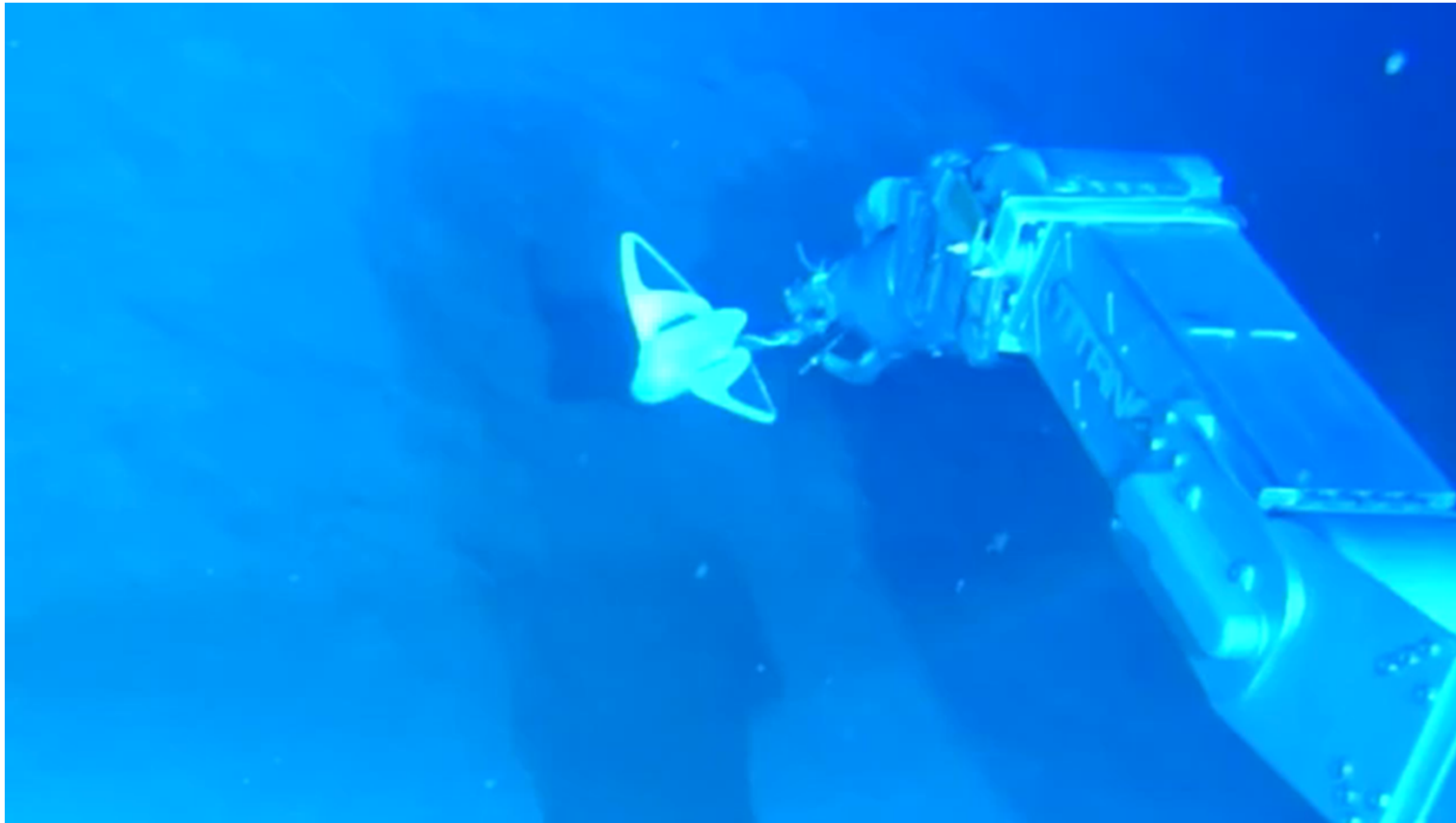

China's soft robot realizes deep sea exploration and free swimming
<https://www.youtube.com/watch?v=QMHy8cl681w>

Li, Guorui, et al. "Self-powered soft robot in the Mariana Trench." *Nature* 591.7848 (2021): 66-71.

Electrically responsive soft actuators: Electroactive polymers: Ionic polymer-metal composites (IPMCs)

- Relies on physical movements of positive ions (cations).
- Large deformation and low voltage but slow. Need of water encapsulation.
- Common material: Nafion (kind of polymer)

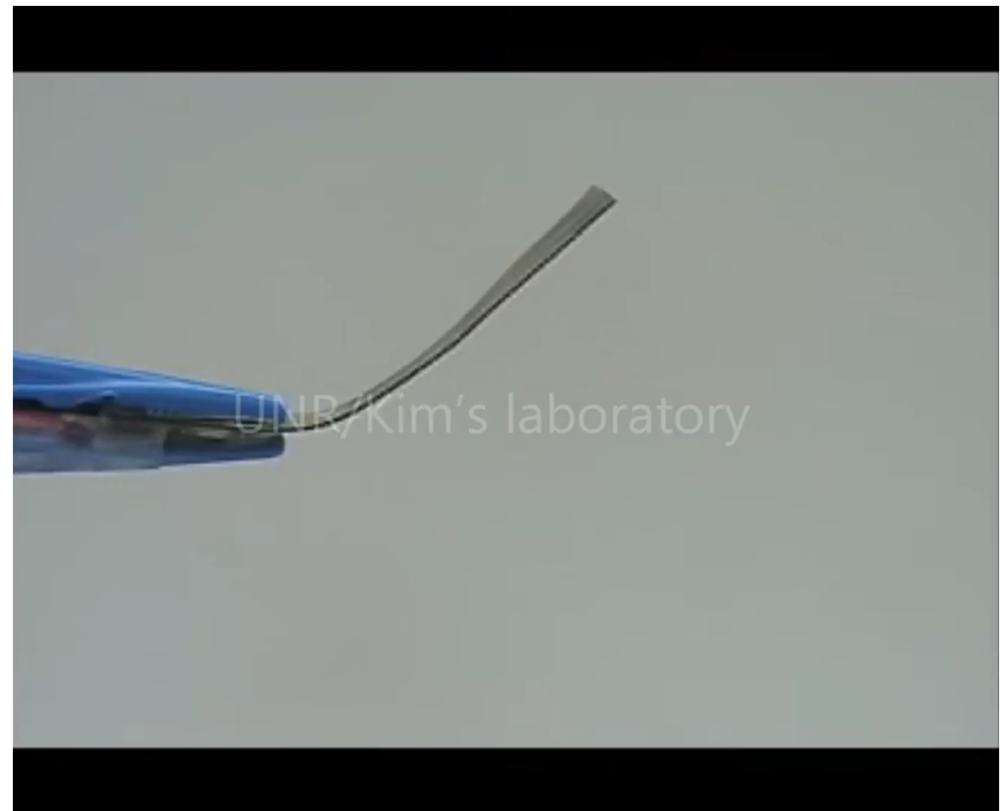
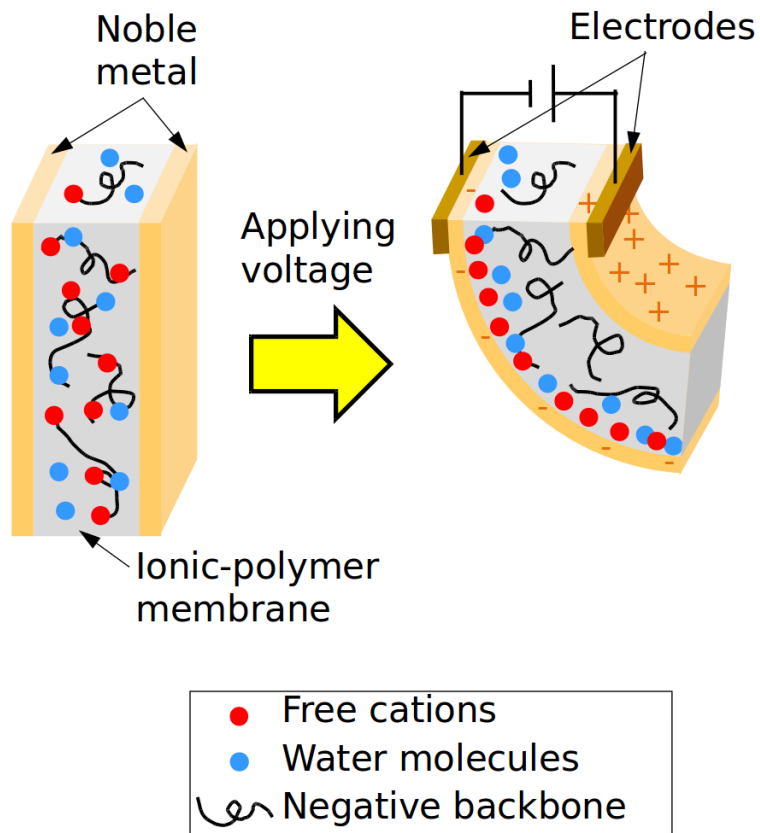

Shahinpoor, Mohsen. "17 Review of Ionic Polymer–Metal Composites (IPMCs) as Smart Materials." *Fundamentals of Smart Materials* (2020): 203.

An ionic polymer-metal composite (IPMC) artificial muscle slowly oscillating at 0.15 Hz
<https://www.youtube.com/watch?v=Nn4b7Wi7RIo>

Electrically responsive soft actuators:
Electroactive polymers:
Ionic polymer-metal composites (IPMCs)

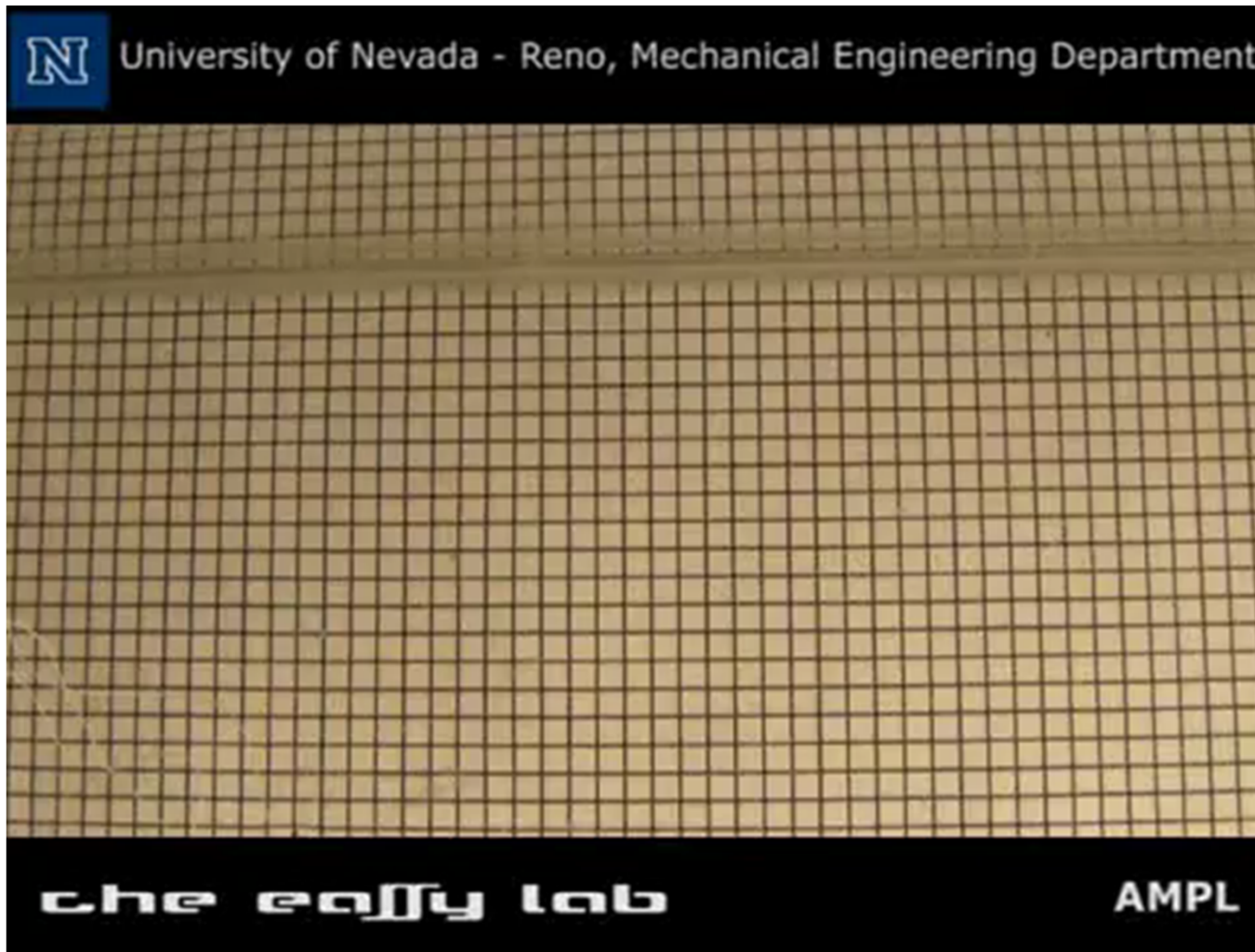

Electrically responsive soft actuators: Electroactive polymers: Ionic polymer-metal composites (IPMCs)

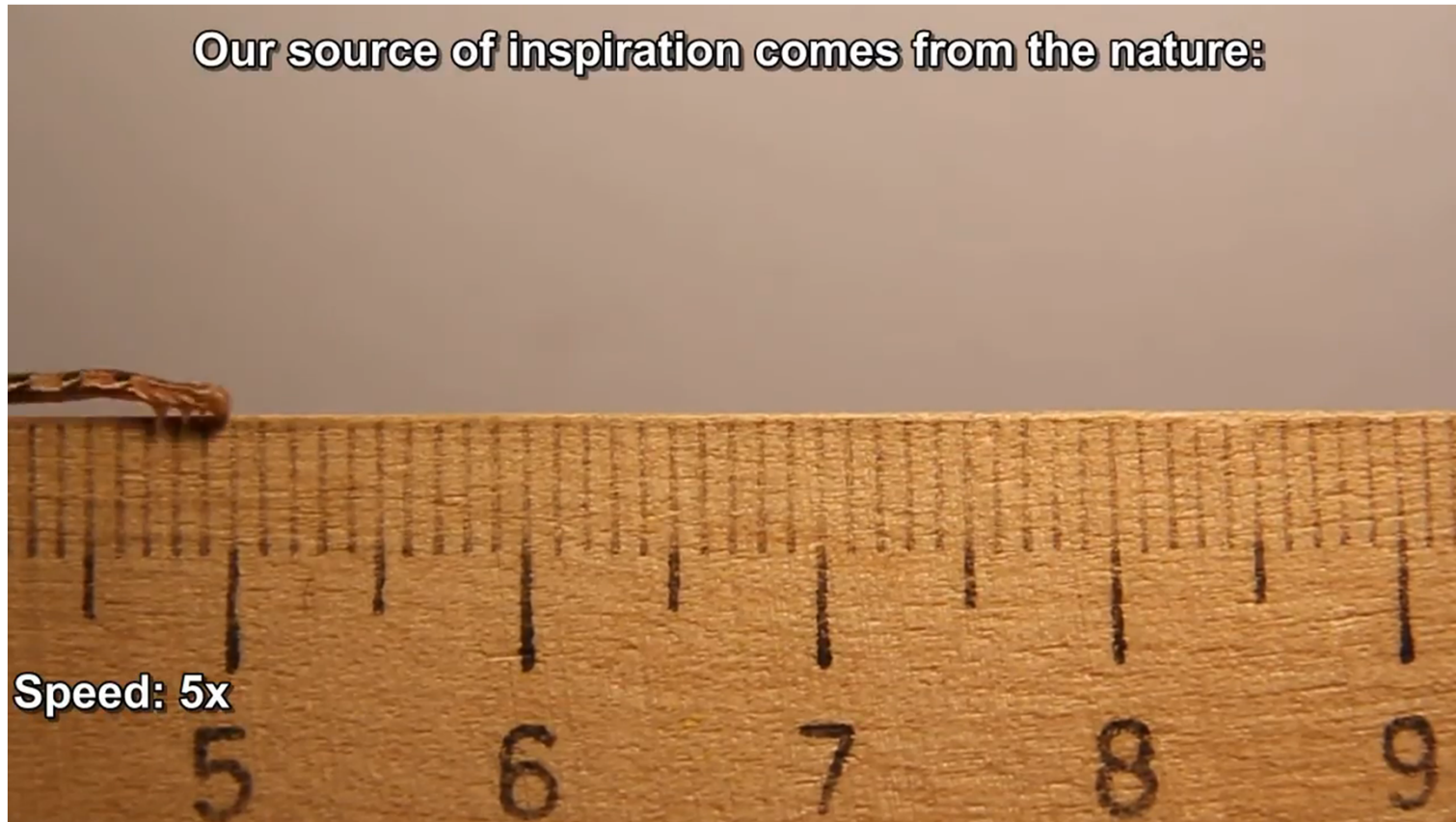

Must, Indrek, et al. "Ionic and capacitive artificial muscle for biomimetic soft robotics." *Advanced Engineering Materials* 17.1 (2015): 84-94.

Ionic and Capacitive Artificial Muscle for Biomimetic Soft Robotics
<https://www.youtube.com/watch?v=1mSMsIQMTnU>

Electrically responsive soft actuators: Electro-hydraulic soft actuators

- Also known as “Hydraulically amplified self-healing electrostatic actuators (HASELs)”.
- Fast, high actuation output but high voltage is required.

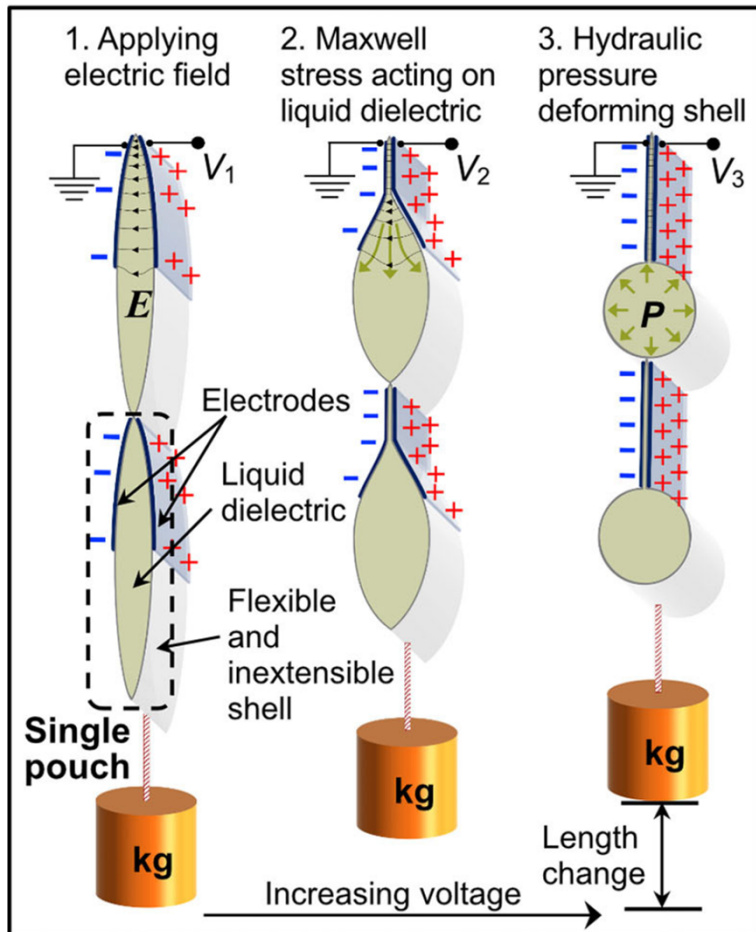

Yoder, Zachary, et al. "Design of a high-speed prosthetic finger driven by Peano-HASEL actuators." *Frontiers in Robotics and AI* (2020): 181.

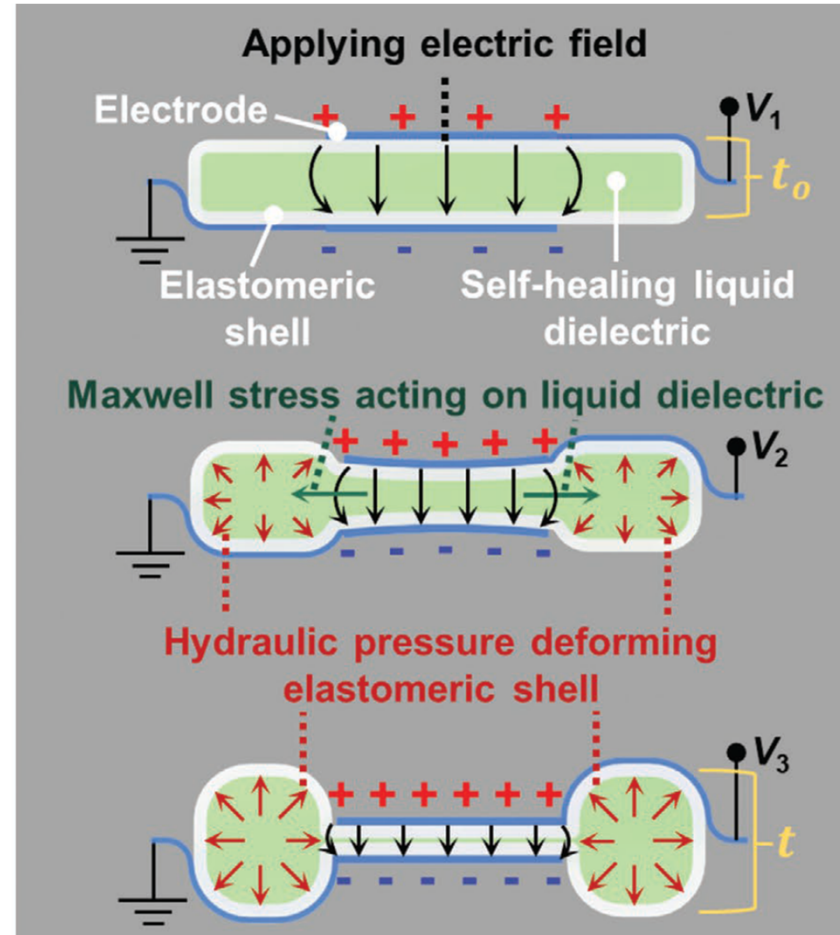

Rothmund, Philipp, et al. "HASEL artificial muscles for a new generation of lifelike robots—recent progress and future opportunities." *Advanced materials* 33.19 (2021): 2003375.

Electrically responsive soft actuators: Electro-hydraulic soft actuators

Peano-HASEL actuators: Muscle-mimetic,
electrohydraulic transducers that linearly
contract on activation

Kellaris, Nicholas, et al. "Peano-HASEL actuators: Muscle-mimetic, electrohydraulic transducers that linearly contract on activation." *Science Robotics* 3.14 (2018): eaar3276.

Peano-HASEL actuators: Muscle-mimetic, electrohydraulic transducers that linearly contract
<https://www.youtube.com/watch?v=k5XH1MDLzi0>

Electrically responsive soft actuators: Electro-hydraulic soft actuators

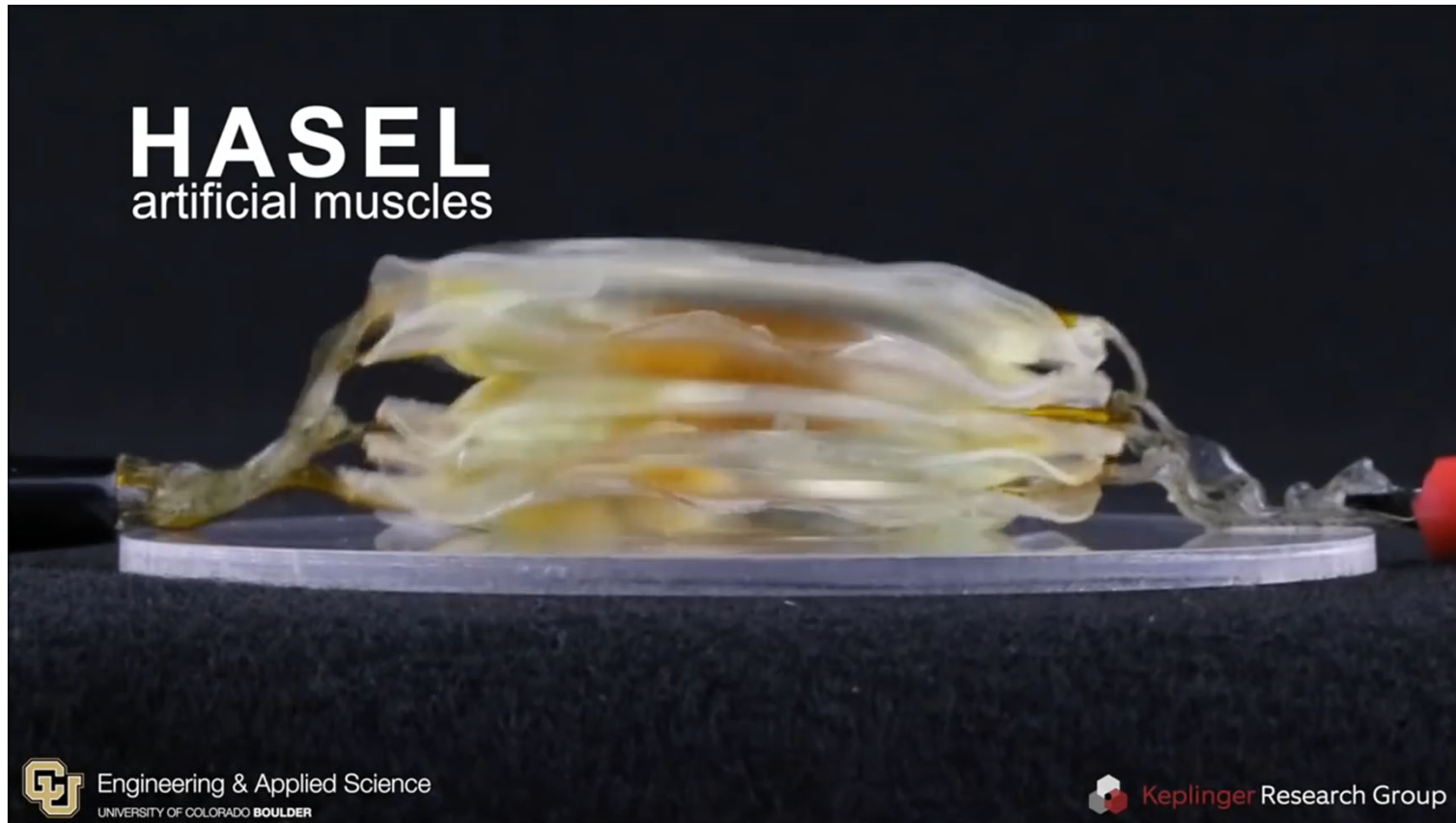

Acome, Eric, et al. "Hydraulically amplified self-healing electrostatic actuators with muscle-like performance." *Science* 359.6371 (2018): 61-65.

HASEL actuators with muscle-like performance
<https://www.youtube.com/watch?v=M4qcvTeN8k0>

Electrically responsive soft actuators: Electro-hydraulic soft actuators

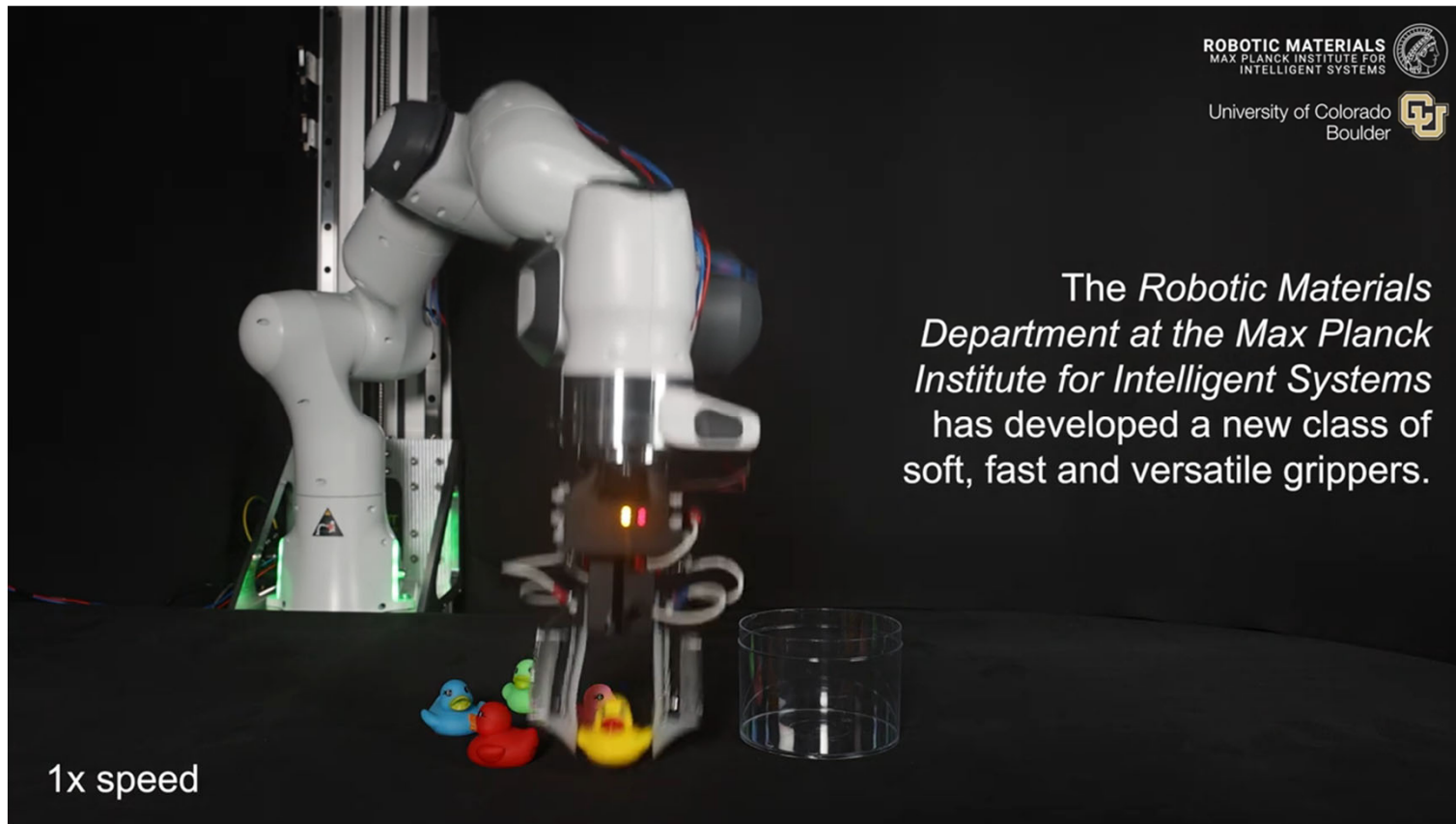

Yoder, Zachary, et al. "A soft, fast and versatile electrohydraulic gripper with capacitive object size detection." *Advanced Functional Materials* 33.3 (2023): 2209080.

A Soft, Fast and Versatile Electrohydraulic Gripper with Capacitive Object Size Detection
https://www.youtube.com/watch?v=wWL5oMK_CRk

Electrically responsive soft actuators: Electro-hydraulic soft actuators



Mitchell, Shane K., Trent Martin, and Christoph Keplinger. "A Pocket-Sized Ten-Channel High Voltage Power Supply for Soft Electrostatic Actuators." *Advanced Materials Technologies* 7.8 (2022): 2101469.

A Pocket-Sized Ten-Channel High Voltage Power Supply for Soft Electrostatic Actuators
<https://www.youtube.com/watch?v=Gh-hbT7Iq6E>

Electrically responsive soft actuators: Biohybrid actuators

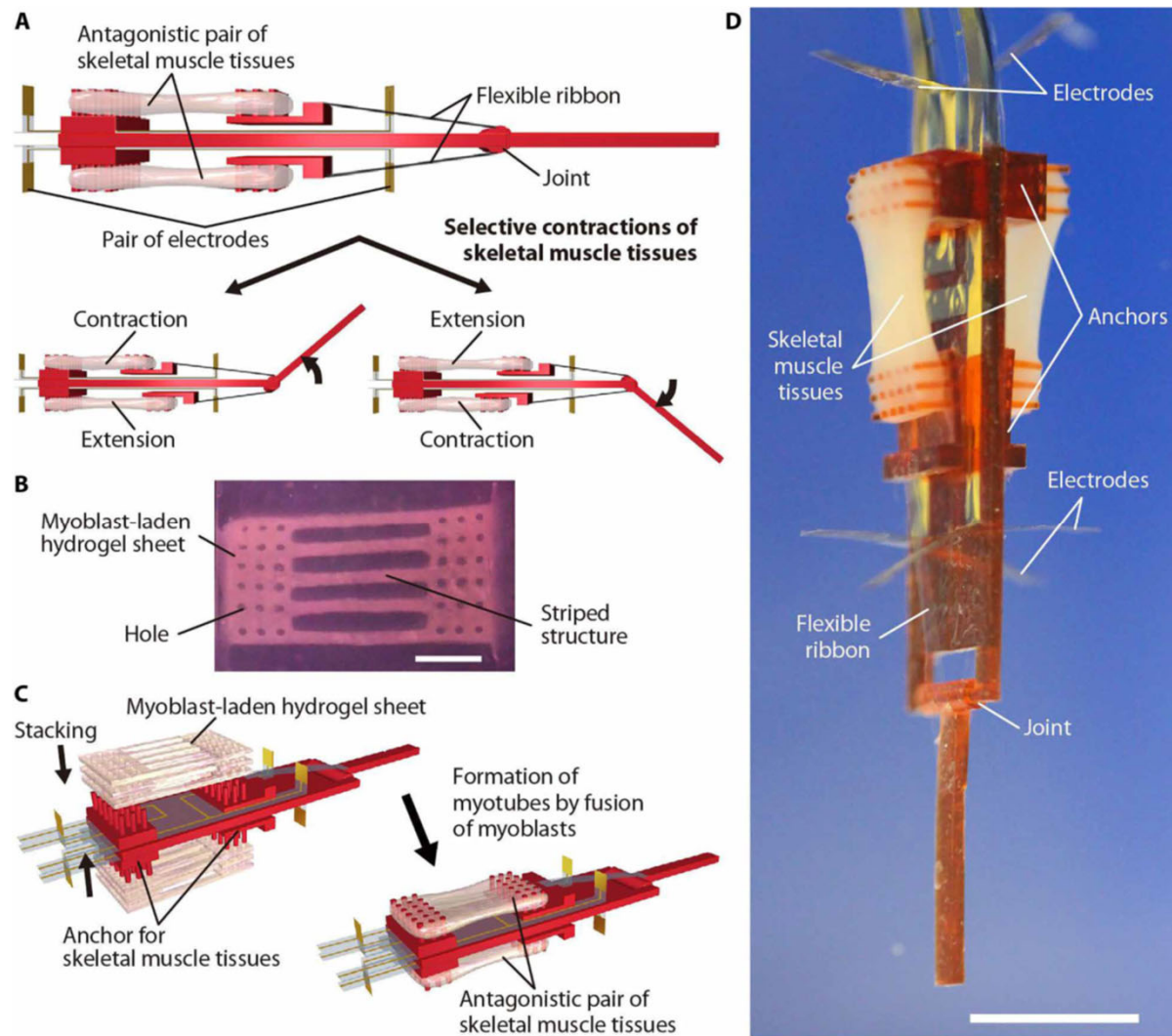

- Exploit movements of cultivated muscle tissue.

Morimoto, Yuya, Hiroaki Onoe, and Shoji Takeuchi. "Biohybrid robot powered by an antagonistic pair of skeletal muscle tissues." *Science robotics* 3.18 (2018): eaat4440.

Electrically responsive soft actuators: Biohybrid actuators

Biohybrid robot powered
by an antagonistic pair
of skeletal muscle tissues

Morimoto, Yuya, Hiroaki Onoe, and Shoji Takeuchi. "Biohybrid robot powered by an antagonistic pair of skeletal muscle tissues." *Science robotics* 3.18 (2018): eaat4440.

Biohybrid robot powered by an antagonistic pair of skeletal muscle tissues
<https://www.youtube.com/watch?v=3UXG4xL0S4g>

Electrically responsive soft actuators: Biohybrid actuators



Park, Sung-Jin, et al. "Phototactic guidance of a tissue-engineered soft-robotic ray."
Science 353.6295 (2016): 158-162.

A Robotic Stingray Harnesses Living Cells
<https://www.youtube.com/watch?v=8Sw6xRAG8XA>

Electrically responsive soft actuators: Biohybrid actuators



Xu, Nicole W., and John O. Dabiri. "Low-power microelectronics embedded in live jellyfish enhance propulsion." *Science Advances* 6.5 (2020): eaaz3194.

Bionic Jellyfish Swim Faster, More Efficiently
<https://www.youtube.com/watch?v=pH5CVb7yjFw>

Thermally responsive soft actuators

- Fishing line artificial muscles
- Shape memory alloys
- Shape memory polymers

Thermally responsive soft actuators: Fishing line artificial muscles

- Also called as “Twisted and coiled polymer (TCP) actuators”.
- Negative thermal expansion causes contraction of twisted fiber.
- High actuation output but slow. Normally require a heating element.
- Common material: Nylon and polyethylene

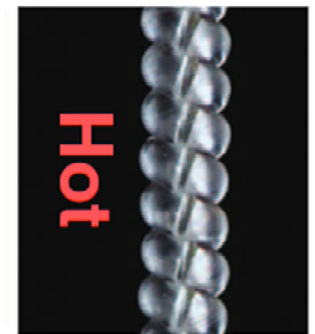
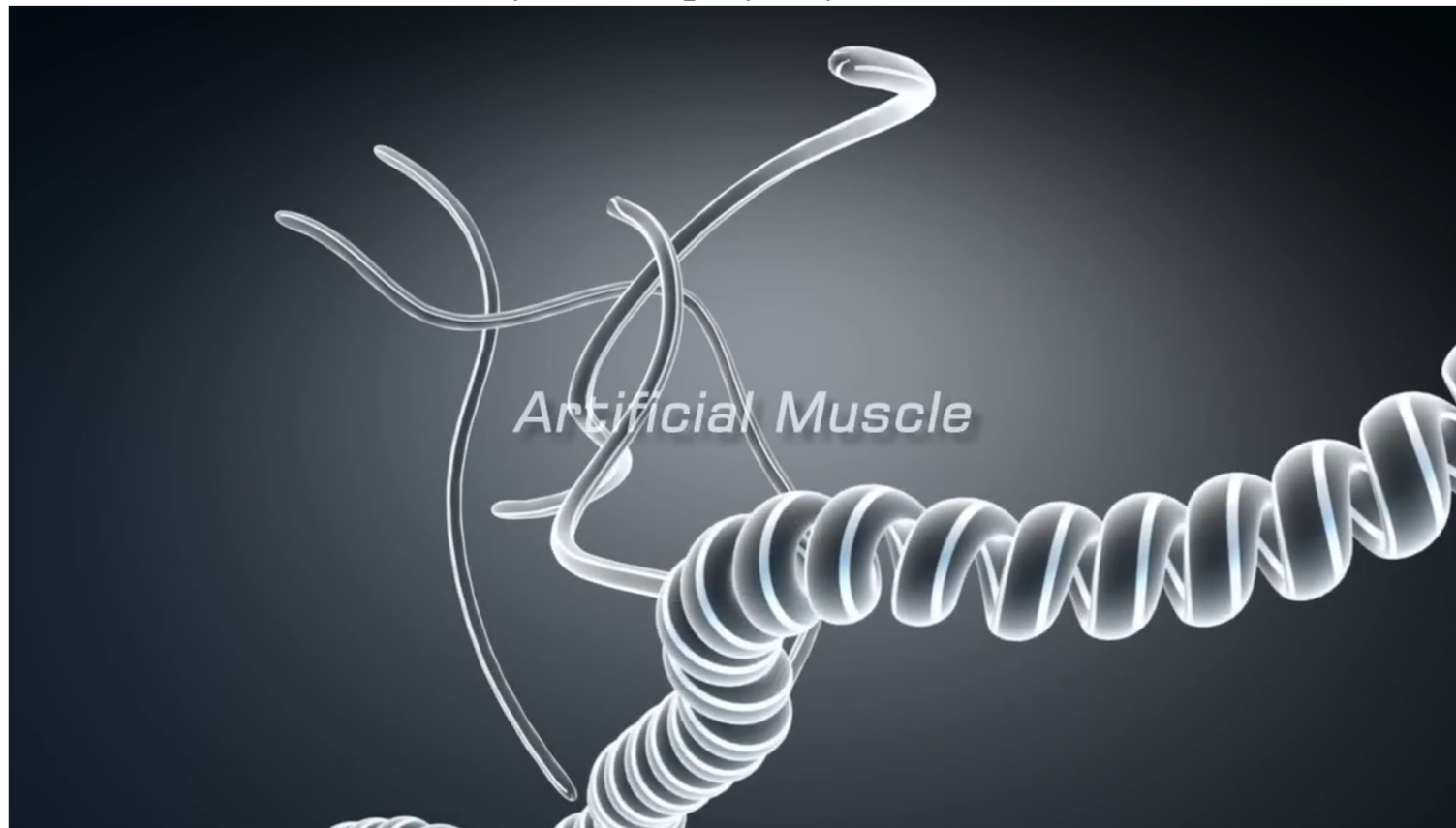

Haines, Carter S., et al. "Artificial muscles from fishing line and sewing thread." science 343.6173 (2014): 868-872.

Fishing Line Artificial Muscles
<https://www.youtube.com/watch?v=Tba8Nf02OSI>

Thermally responsive soft actuators: Fishing line artificial muscles

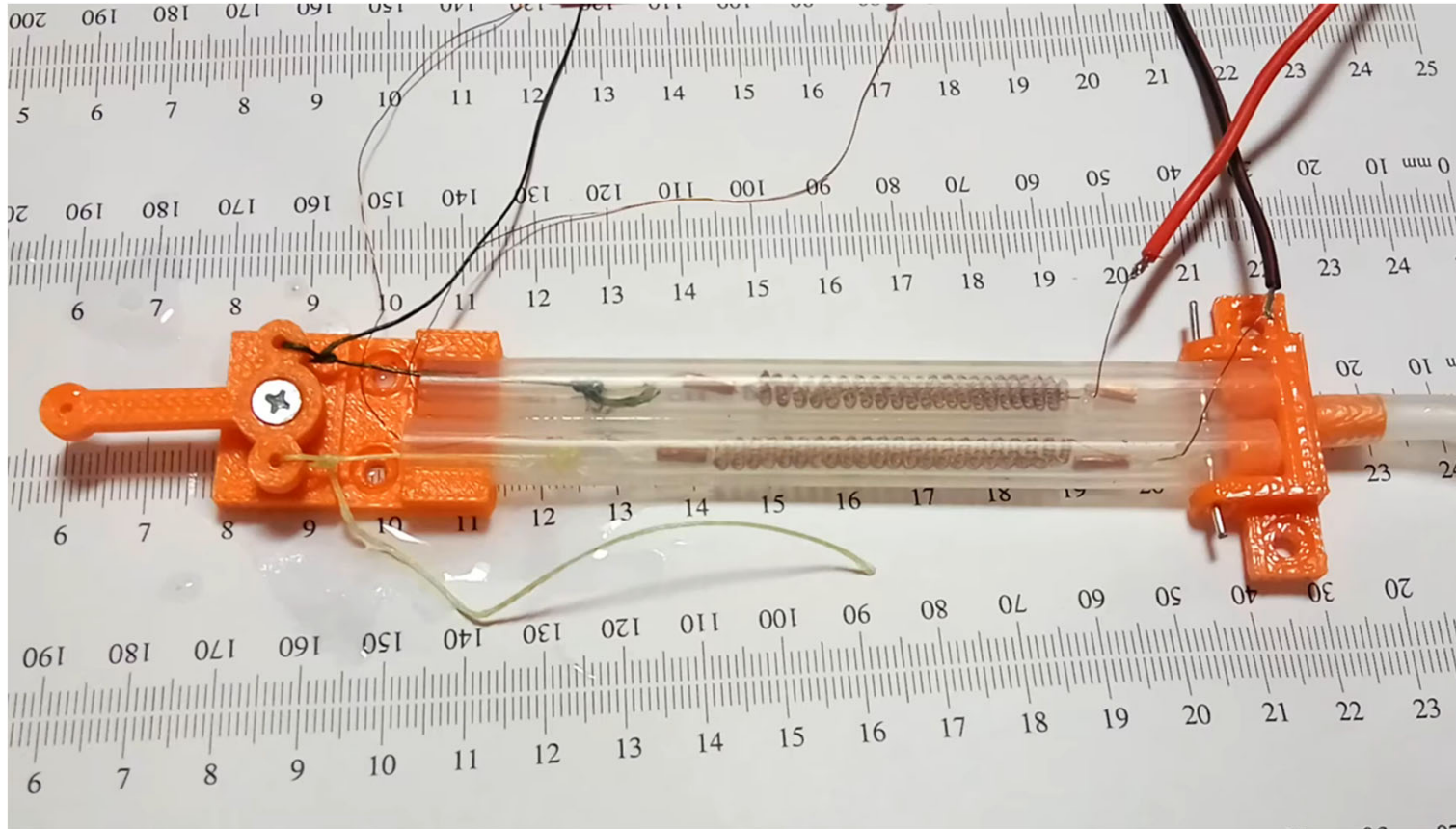

Semochkin, Aleksandr N. "A device for producing artificial muscles from nylon fishing line with a heater wire." 2016 IEEE International Symposium on Assembly and Manufacturing (ISAM). IEEE, 2016.

Artificial Muscles from Fishing Line in action
<https://www.youtube.com/watch?v=UbvNW7ONiTc>

Thermally responsive soft actuators: Fishing line artificial muscles

360° View

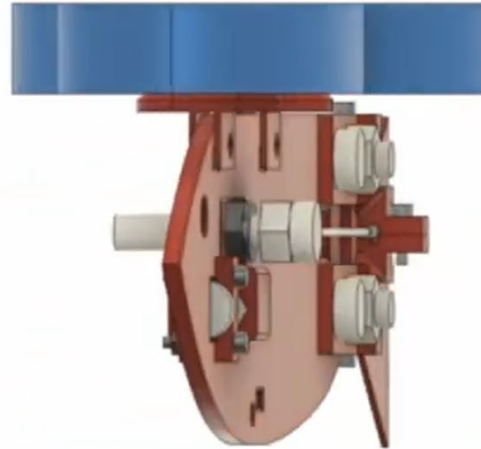

Thermally responsive soft actuators: Fishing line artificial muscles

TCA with Free Stroke

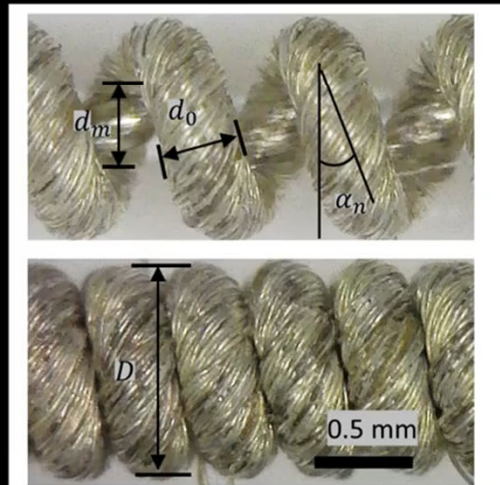

Sun, Jiefeng, et al. "Twisted-and-coiled actuators with free strokes enable soft robots with programmable motions." *Soft robotics* 8.2 (2021): 213-225.

Soft Robots Driven by Twisted-and-Coiled Actuators
<https://www.youtube.com/watch?v=i8mjU3i3QWE>

Thermally responsive soft actuators: Shape memory alloys

- Crystallographic change induced by temperature between martensite and austenite states.
- High actuation output with moderate speed. Temperature can be applied by Joule-heating.
- Common material: Nickel-Titanium (Nitinol) alloy

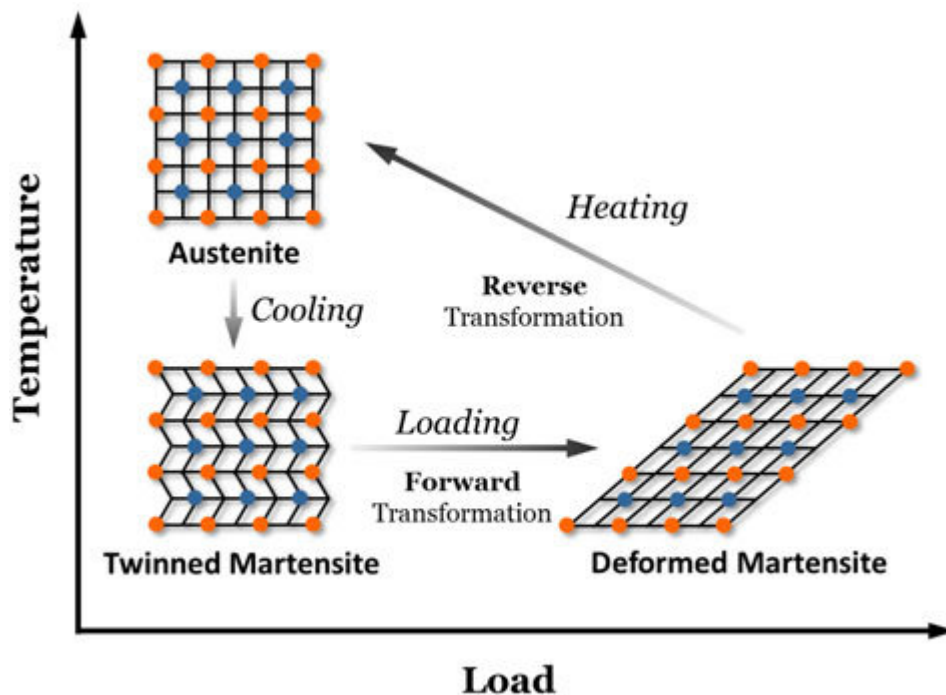

Chu, Won-Shik, et al. "Review of biomimetic underwater robots using smart actuators." International journal of precision engineering and manufacturing 13 (2012): 1281-1292.

Shape Memory Alloy Demo
<https://www.youtube.com/watch?v=231O7jlgwXI>

Thermally responsive soft actuators: Shape memory alloys

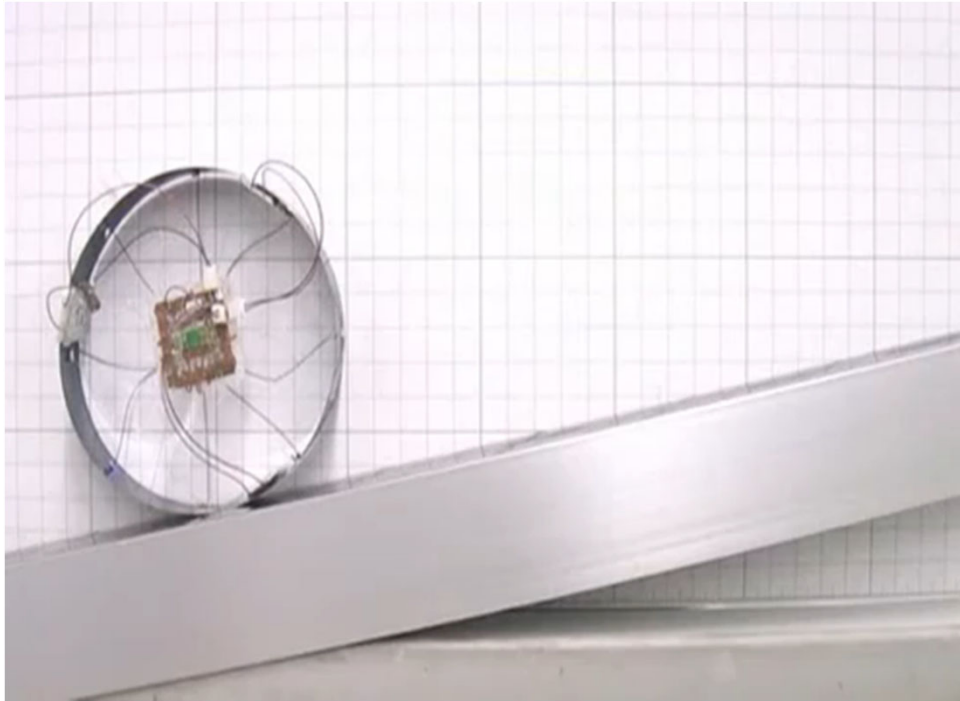

Circular soft robot with built-in power source
<https://www.youtube.com/watch?v=FOdeaMbJPmE>

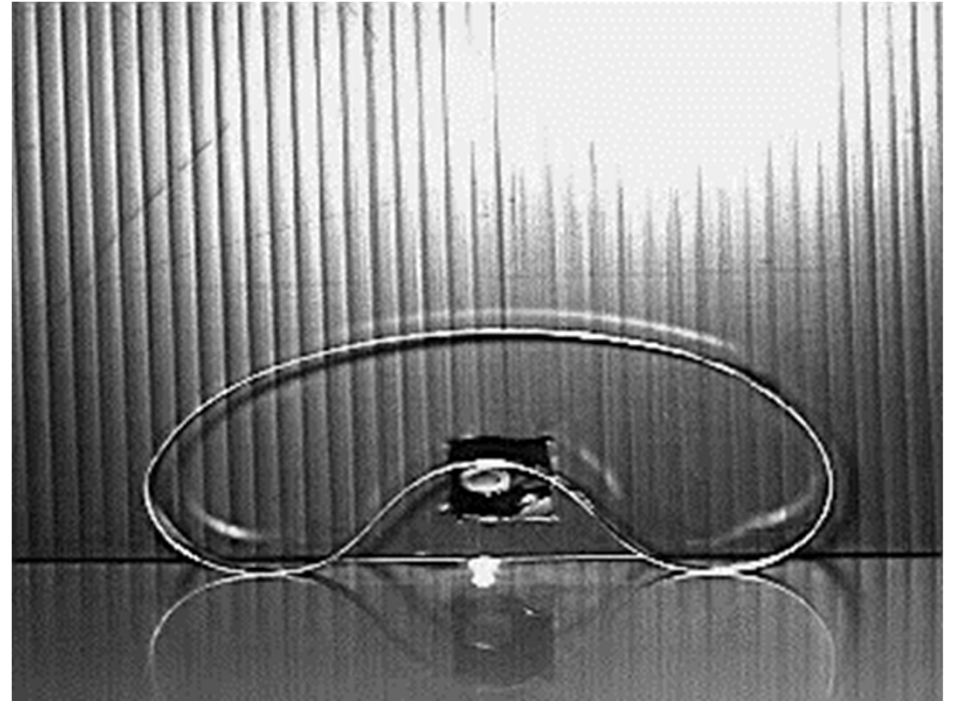

Jump from Cap shape
<https://www.youtube.com/watch?v=V6TjMazI9W4>

Thermally responsive soft actuators: Shape memory alloys



Koh, Je-Sung, et al. "Jumping on water: Surface tension–dominated jumping of water striders and robotic insects." *Science* 349.6247 (2015): 517-521.

Robot Jumps Off Water- Emulating the natural locomotion of water strider insects
<https://www.youtube.com/watch?v=yqX0V2LDWog>

Thermally responsive soft actuators: Shape memory alloys

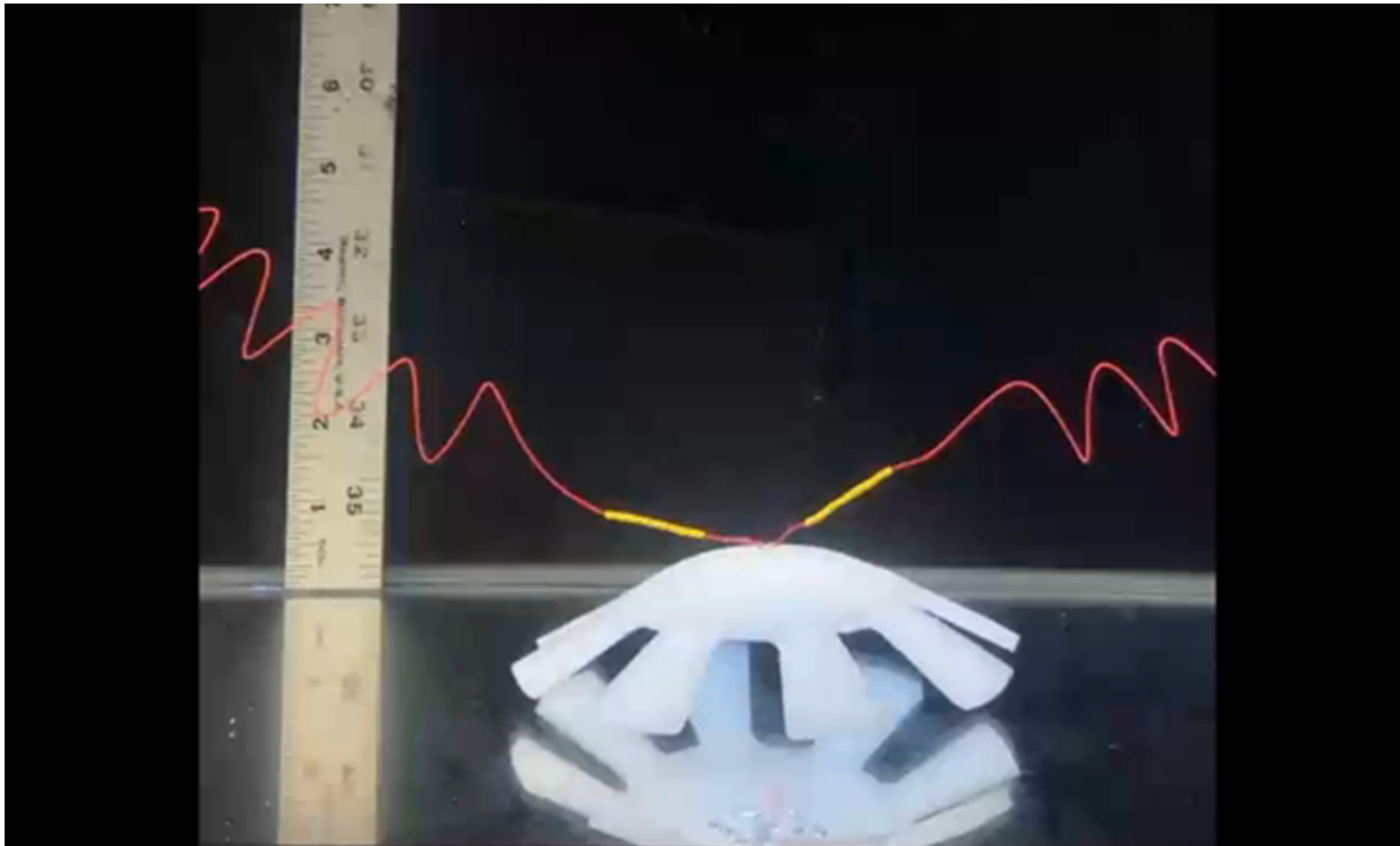

Kazemi-Lari, Mohammad AA, et al. "Robotic jellyfish actuated with a shape memory alloy spring."
Bioinspiration, Biomimetics, and Bioreplication IX. Vol. 10965. SPIE, 2019.

Robotic jellyfish actuated with a shape memory alloy spring
<https://www.youtube.com/watch?v=GT-6qOqzTVs>

Thermally responsive soft actuators: Shape memory polymers

- Polymers that become rubbery state at certain temperature turn into soft and back to its initial shape when it is heated from a deformed shape.
- Actuation can be large but mostly slow. Need a heating element.
- Common material: Thermoplastic polyurethane (TPU)

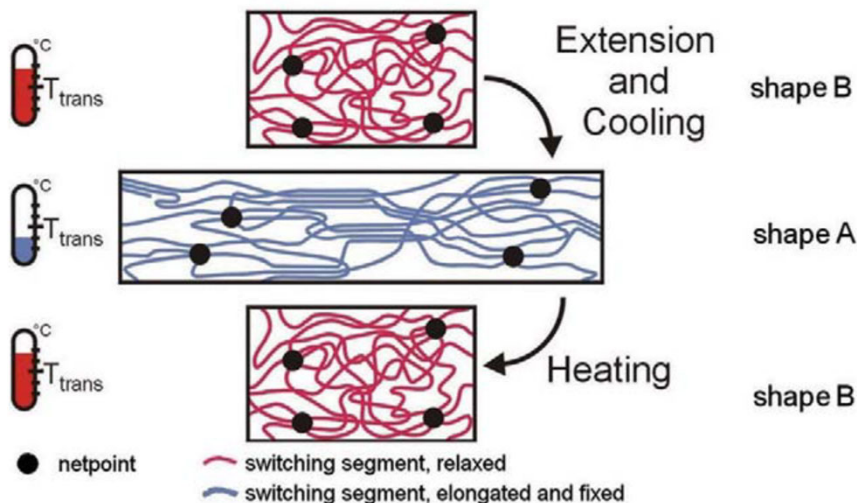

Lendlein, Andreas, and Steffen Kelch. "Shape-memory polymers." *Angewandte Chemie International Edition* 41.12 (2002): 2034-2057.

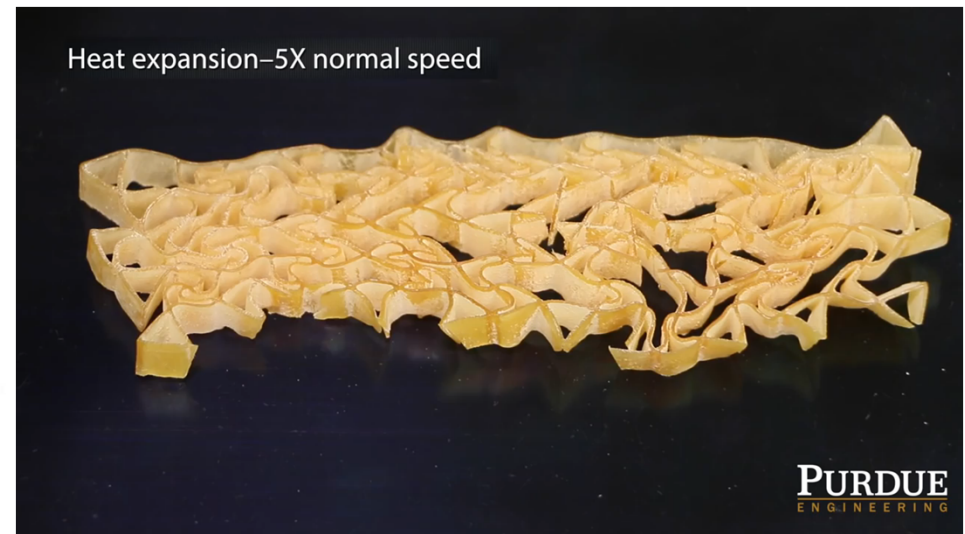

Programmable Materials: Shape-Memory Polymers
<https://www.youtube.com/watch?v=abGAVzueSUC>

Thermally responsive soft actuators: Shape memory polymers

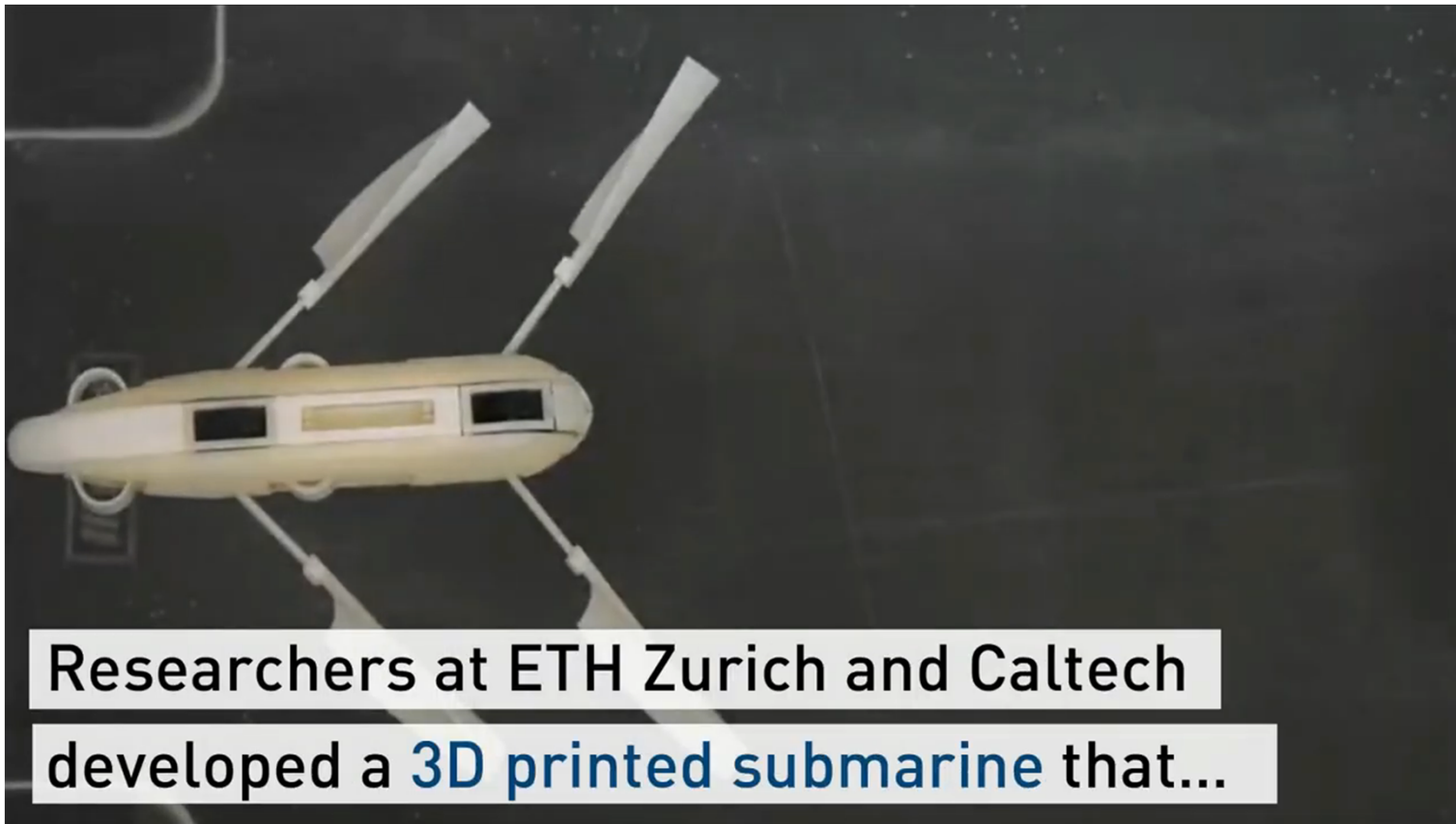

Chen, Tian, et al. "Harnessing bistability for directional propulsion of soft, untethered robots." Proceedings of the National Academy of Sciences 115.22 (2018): 5698-5702.

Motorless submarine
<https://www.youtube.com/watch?v=ulF1xEfCHBs>

Thermally responsive soft actuators: Shape memory polymers

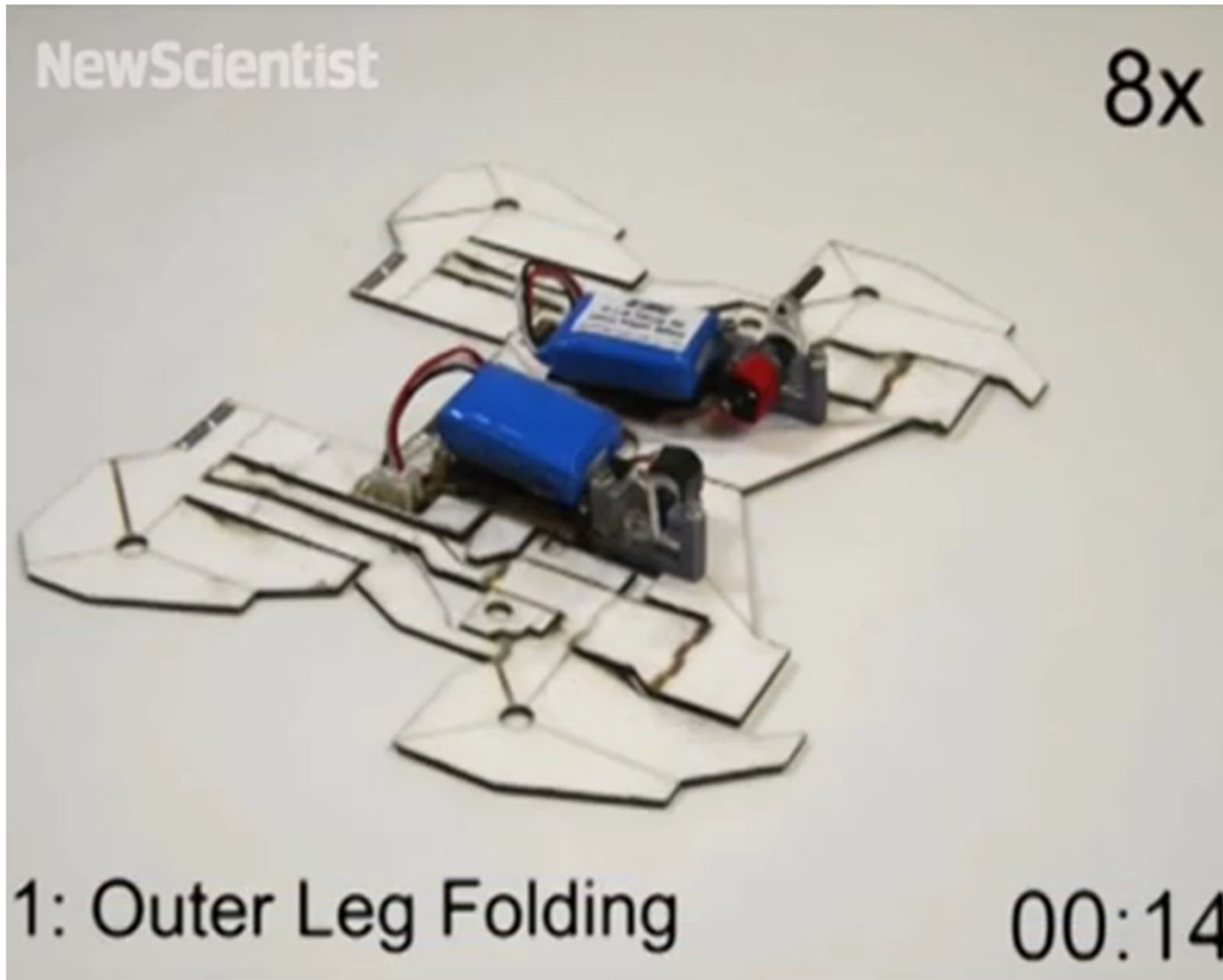

Magnetically responsive soft actuators: Magnetic elastomer actuators

- Embed/mix ferromagnetic materials/magnets into soft materials.
- Fast, moderate actuation output, external magnetic field required.

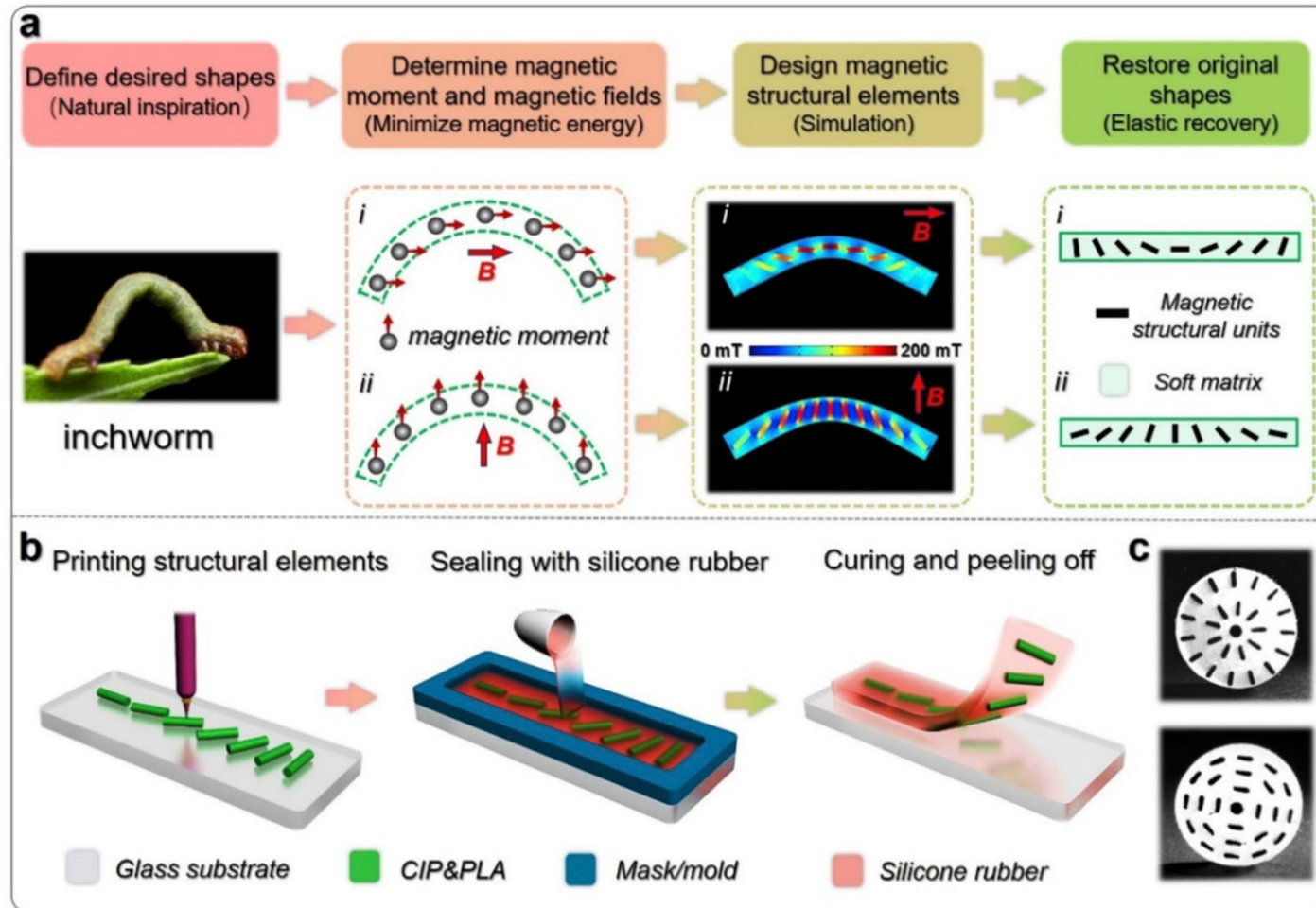

Qi, Song, et al. "3D printed shape-programmable magneto-active soft matter for biomimetic applications." *Composites Science and Technology* 188 (2020): 107973.

Magnetically responsive soft actuators: Magnetic elastomer actuators

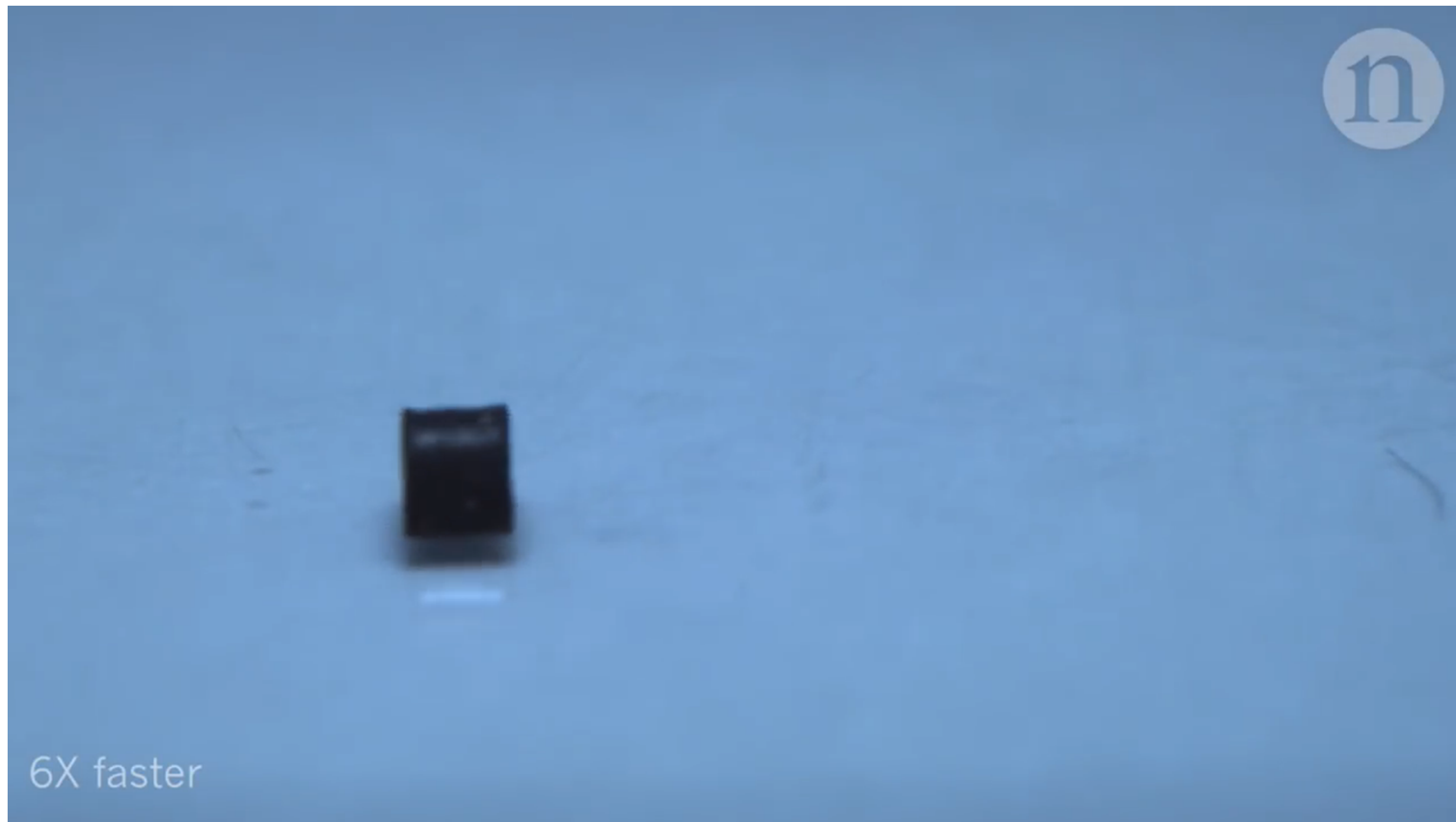

Hu, Wenqi, et al. "Small-scale soft-bodied robot with multimodal locomotion."
Nature 554.7690 (2018): 81-85.

A mini, magnetic, all-terrain robot
<https://www.youtube.com/watch?v=OXRmxuB60DQ>

Magnetically responsive soft actuators: Magnetic elastomer actuators

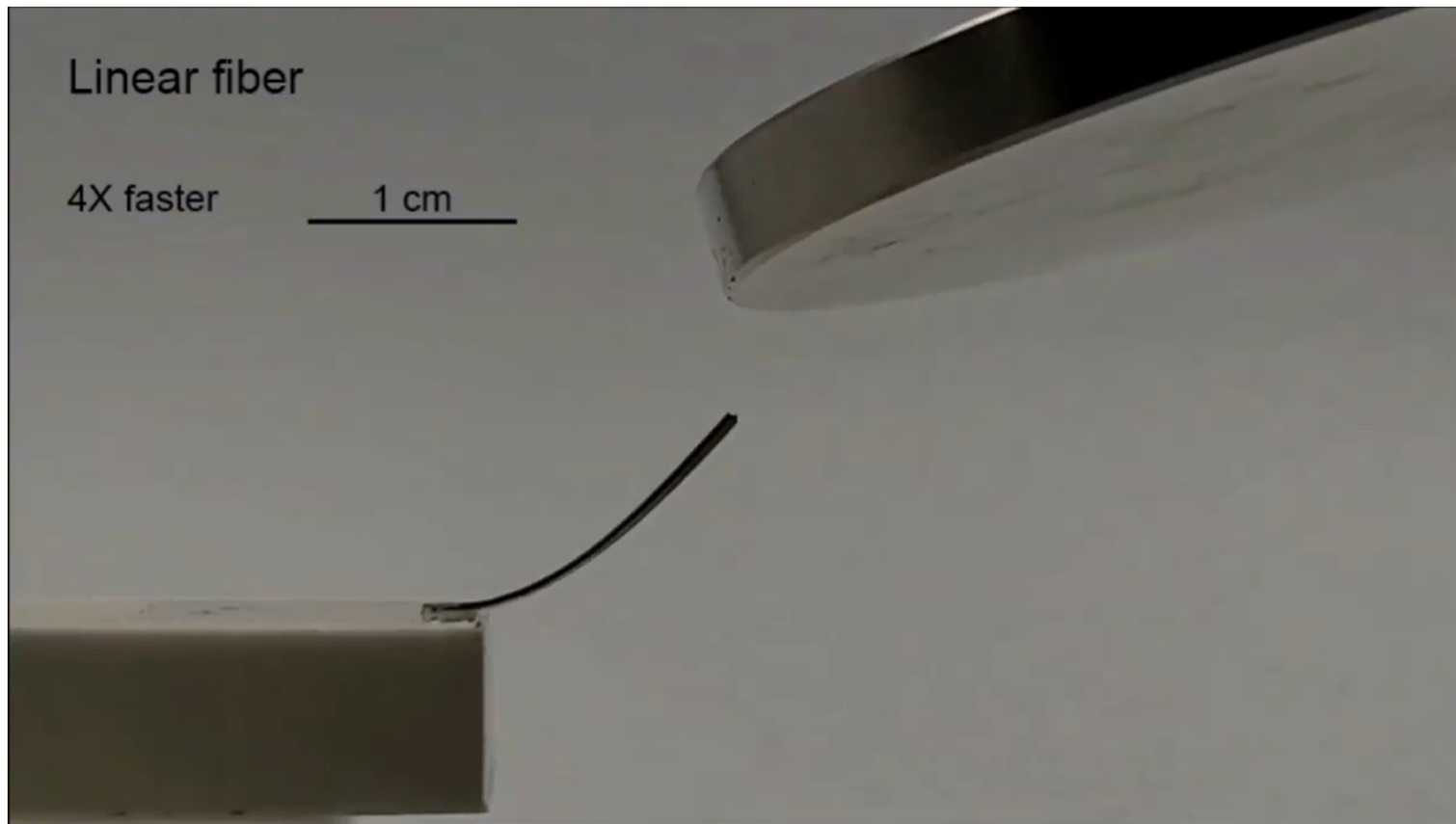

Lee, Youngbin, et al. "Magnetically Actuated Fiber-Based Soft Robots." *Advanced Materials* 35.38 (2023): 2301916.

Creating magnetic soft robots using fiber-based processes and unidirectional magnetic fields
<https://www.youtube.com/watch?v=dQlXeYN57wk>

Pros and cons; Yet no perfect soft actuator.

	Pros	Cons
<ul style="list-style-type: none"> • Pressure responsive <ul style="list-style-type: none"> • Fluidic elastomer actuators • McKibben actuators • Film based soft actuators 	<p>High actuation output Relatively fast</p>	<p>External pumps and compressors</p>
<ul style="list-style-type: none"> • Electrically responsive <ul style="list-style-type: none"> • Electroactive polymers • Electro-hydraulic soft actuators • Biohybrid actuators 	<p>High actuation output Fast (excl. ion-type)</p>	<p>High voltage required (excl. ion-type)</p>
<ul style="list-style-type: none"> • Thermally responsive <ul style="list-style-type: none"> • Fishing line artificial muscles • Shape memory alloys • Shape memory polymers 	<p>High actuation output</p>	<p>Slow External heating</p>
<ul style="list-style-type: none"> • Magnetically responsive <ul style="list-style-type: none"> • Magnetic elastomer actuators 	<p>Moderate actuation output Fast</p>	<p>External magnetic fields</p>

References

- Rus, Daniela, and Michael T. Tolley. "Design, fabrication and control of soft robots." *Nature* 521.7553 (2015): 467-475.
- Rich, Steven I., Robert J. Wood, and Carmel Majidi. "Untethered soft robotics." *Nature Electronics* 1.2 (2018): 102-112.
- Wallin, T. J., James Pikul, and Robert F. Shepherd. "3D printing of soft robotic systems." *Nature Reviews Materials* 3.6 (2018): 84-100.
- Gorissen, Benjamin, et al. "Elastic inflatable actuators for soft robotic applications." *Advanced Materials* 29.43 (2017): 1604977.
- Hines, Lindsey, et al. "Soft actuators for small-scale robotics." *Advanced materials* 29.13 (2017): 1603483.
- El-Atab, Nazek, et al. "Soft actuators for soft robotic applications: A review." *Advanced Intelligent Systems* 2.10 (2020): 2000128.
- Li, Meng, et al. "Soft actuators for real-world applications." *Nature Reviews Materials* 7.3 (2022): 235-249.
- Shen, Zequn, et al. "Stimuli-responsive functional materials for soft robotics." *Journal of Materials Chemistry B* 8.39 (2020): 8972-8991.

Homework

Provide a report of at least one page containing the following points.

- Pick a specific soft actuator technology and then propose a soft robot or soft robotic application based on it.
- Explain the originality or novelty of what you proposed.
- Explain the reasons behind choosing the soft actuator technology and how it helps the proposed device.

Report should be provided within PDF format. It should include your name and student ID number.

Deadline: Dec. 8th

Language: EN or JP